

Torque of Screws		
Type	AF	Torque
A	14mm hex socket screw	150 Nm
B	1 3/16" hexagon screw / nut	100 Nm
C	13/16" hexagon screw / nut	55 Nm
D	5/8" hexagon screw / nut	30 Nm
E	17mm hexagon screw / nut	30 Nm

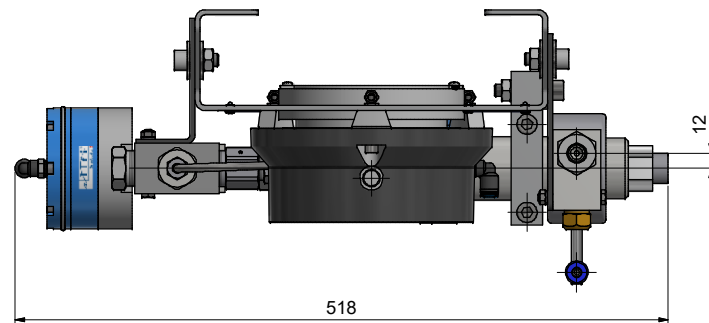

Item	Qty	Description	Part-Number	Characteristics	Weight
1	1	Hand Valve 2-Way Straight 9/16" 2.0 Imp	910210-I		1270 g
2	1	HD-Filter 9/16" Imp - 70my	939170-I		5309 g
3	1	Pneum. Valve 2-Way Angle 9/16" NC 2.0 Imp	910570-I		2541 g
4	1	Cross 9/16" Imp	409191A-I		143 g
5	1	Pressure relief valve 3/8" Imp	919110-I		1501 g
6	1	High Pressure Gauge 6000bar	933000		5000 g
7	1	Reducer m/f 9/16" - 1/4" Imp	659114-I		242 g
8	1	Reduction 9/16" - 3/8" Imp.	659138A-I		231 g
9	1	Adjustable double Nipple 3/8" Imp	613838-I		128 g
10	2	Gland Nut 9/16" Imp	709107		14 g
11	2	Collar 9/16"	719100	Not Visible	29 g
12	2	HD-Tube 9/16" L=91	809102-0091		95 g
13	1	HD-Tube 9/16" L=120	809102-0120		128 g
14	1	HD-Tube 1/4" bend	801502		77 g
15	1	HP-tube 1/4" L=75	803800-0075		36 g
16	1	Frame	982011		7155 g
17	1	Fixing bracket	982006		99 g
18	2	Clamp for 939100	982008		756 g
19	1	Bracket	982013		303 g
20	1	Support	982012		262 g
21	4	Hex head bolt ISO 4014 M6x50-A2	000502		14 g
22	2	Hex Socket Screw M10 x 100 - A2	000506		75 g
23	2	Hex Socket Head Cap Screw ISO 4762 M10x45-A2	000508		40 g
24	4	Hex Socket Head Cap Screw ISO 4762 M10x25-A2	000088		4 g
25	3	Hex Socket Screw M6 x 40 - A2	000036		12 g
26	2	Hex Socket Head Cap Screw ISO 4762 M6x16-A2	000059		7 g
27	3	Hex Socket Head Cap Screw M6 x 12 - A2	000034		6 g
28	8	Hexagon Nut M10 - A2	000094		1 g
29	9	Hexagon Nut M6 - A2	000047		3 g
30	10	Flat Washer 10,5 / 30 x 2,5 - A2	000167		12 g
31	11	Flat Washer 6,4 / 11 x 1,6 - A2	000040		1 g
32	4	Signs	051056		2 g
33	8	Blind rivet 3,2mm	000512		0 g
34	1	Warning sticker	-		1 g
35	2	Push-In Fitting 8mm 90°	030148		15 g

General tolerances ISO 2768-1 mK

Amendment: A) 2x Pos. 35 neu, 20.06.2023 AM

Replace for: -
Replaced by: -
Drawn: 30.10.2018 AM
Checked: 16.01.2019 RB
Release: 16.01.2019 RB
Index-release: 20.06.2023 HL

Block & Bleed Imp

Scale: 1 : 3

Max. 4150 bar / 60,000 psi

982000-I

ALLFI AG - RIEDENMATT 1 - CH-6370 STANS
PHONE +41(0)41-618 05 05
E-MAIL: sales@allfi.com

Index: A
Sheet No.: 1
No. of sheets: 1

http://www.allfi.com