

# Maintenance / Assembly

This drawing is Appendix A of the installation and maintenance instructions "Abrasive Feeder 2.0". The complete installation and maintenance instruction is hosted at [www.allfi.com](http://www.allfi.com)

# Wartung / Montage

Diese Zeichnung ist Anhang A der Montage- und Wartungsanleitung "Abrasive Dosierung 2.0". Komplette Betriebsanleitung unter [www.allfi.com](http://www.allfi.com)

Deutsch:

English:

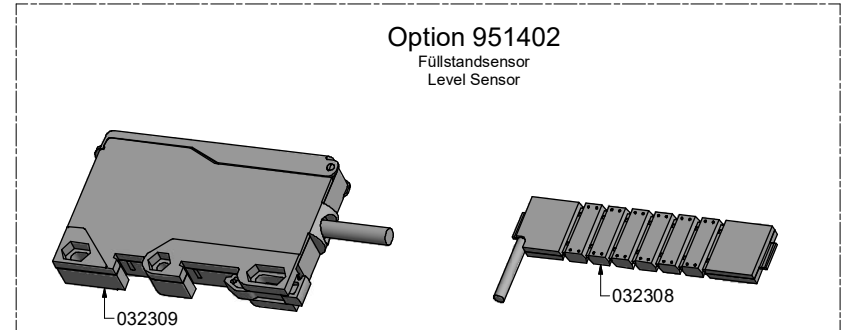
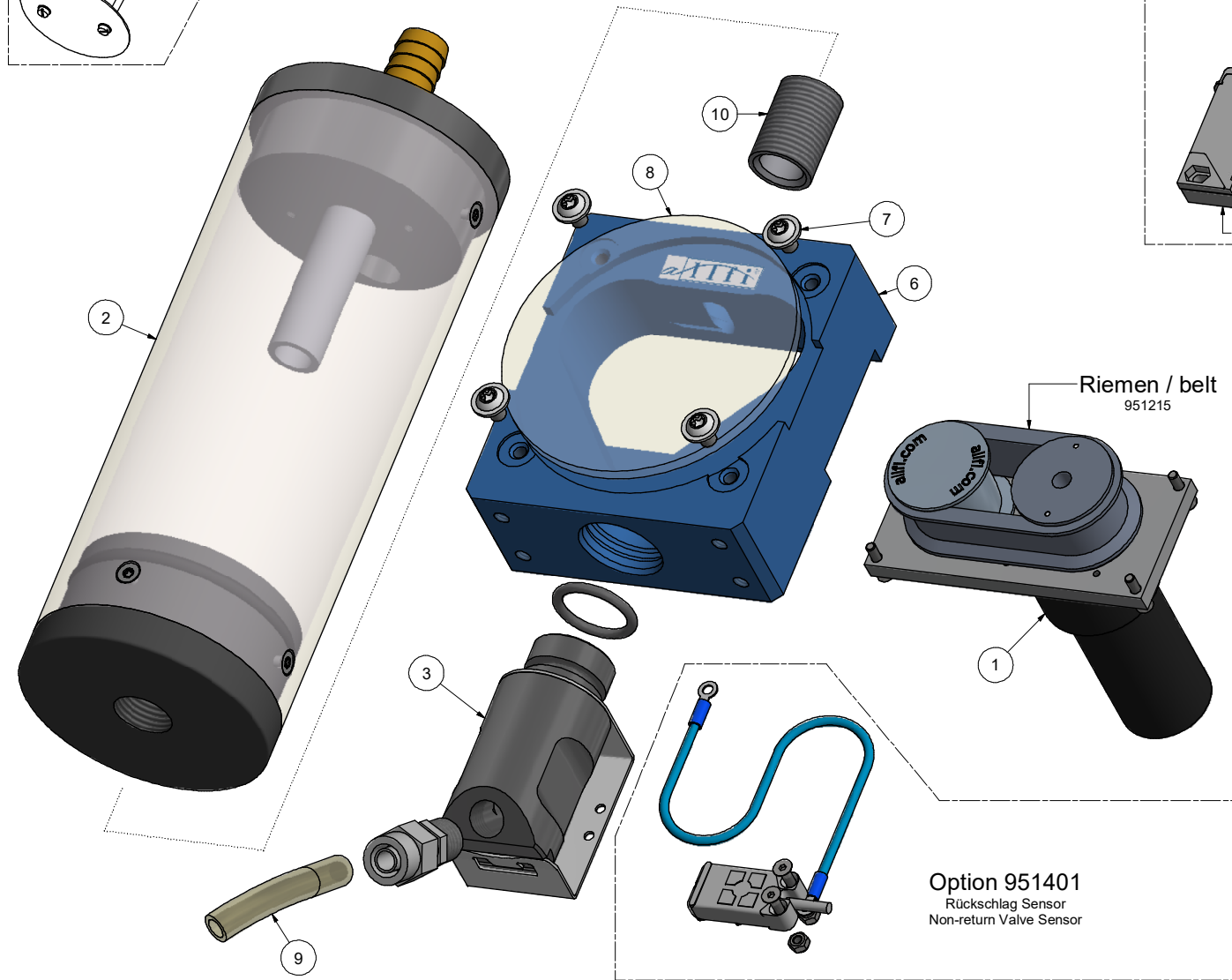
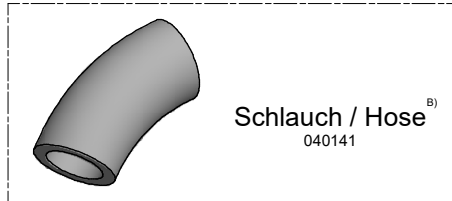
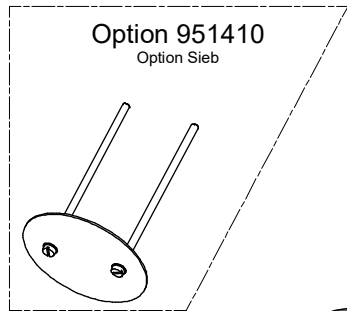

Pos.	Stk.	Gegenstand	Artikel	Kommentare	Gewicht
1	1	Motorbaugruppe Maxon	951405		491.5 g
2	1	Behälter Dosierung 2.0	951404		731 g
3	1	Rückflussverhinderer	951407		98.2 g
4	1	Linear Servo Controller	951217	Nicht abgebildet	380 g
5	1	Buchse Set zu Motorenanschluss	951226	Nicht abgebildet	4.5 g
6	1	Gehäuse Dosierung 2.0	951451		527.1 g
7	4	Schraube M5	000632	C)	0.3 g
8	1	Sichtscheibe	951460		33 g
9	1	Polyurethanschlauch	040025	2,5m	126 g
10	1	Einlaufrohr Gehäuse	951456		34.6 g

Item	Qty	Description	Part-Number	Comments	Weight
1	1	Motor Assembly Maxon	951405		491.5 g
2	1	Sand container 2.0	951404		731 g
3	1	Back Flow Preventer	951407		98.2 g
4	1	Linear Servo Controller	951217	Not shown	380 g
5	1	Connector for Engine Connection	951226	Not shown	4.5 g
6	1	Case Feeder 2.0	951451		527.1 g
7	4	Screw M5	000632	C)	0.3 g
8	1	Viewing windows	951460		33 g
9	1	Hose	040025	2,5m	126 g
10	1	Inlet pipe case	951456		34.6 g

General tolerances ISO 2768-1 m. Designs and drawings created and produced by the contractor are the contractor's intellectual property and may only be used for the purposes of the order.

Amendment:		Replace for:
A) Housing simplified, options redesigned, assembly pos. 6 new, 09.04.2019 AM		Replaced by:
B) Schlauch/Hose was 040031, 29.09.2021 AM		Drawn: 06.04.2018 AM
C) Pos 7 was 040032, 08.11.2021 AM		Checked: 29.04.2019 BT
		Release: 24.09.2019 RB
		Index-release: 08.11.2021 RB

Abrasive Feeder / Abrasivdosierung 2.0

Scale //



ALLFI AG - RIEDENMATT 1 - CH-6370 STANS  
PHONE +41(0)41-618 05 05  
E-MAIL: [sales@allfi.com](mailto:sales@allfi.com)

<http://www.allfi.com>

951400

Index Sheet No. of sheets 1 2

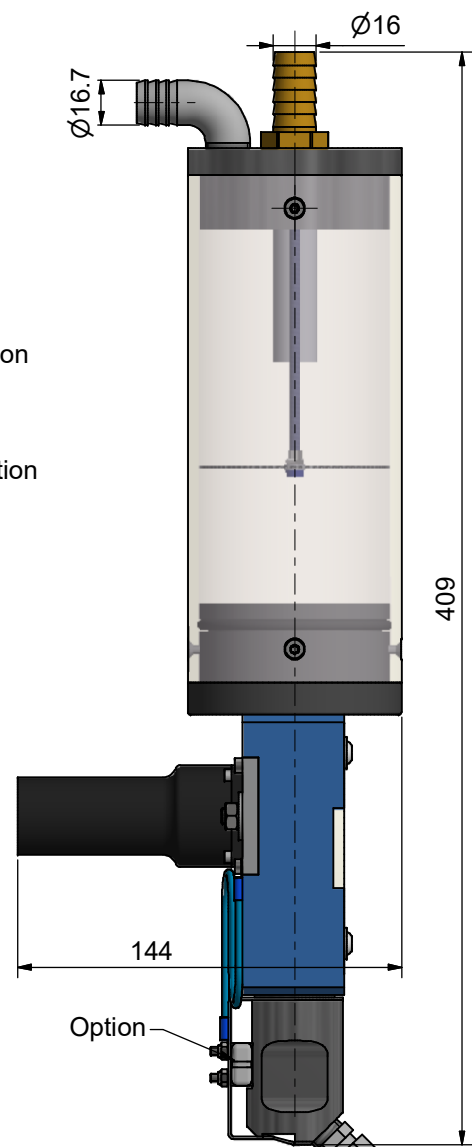
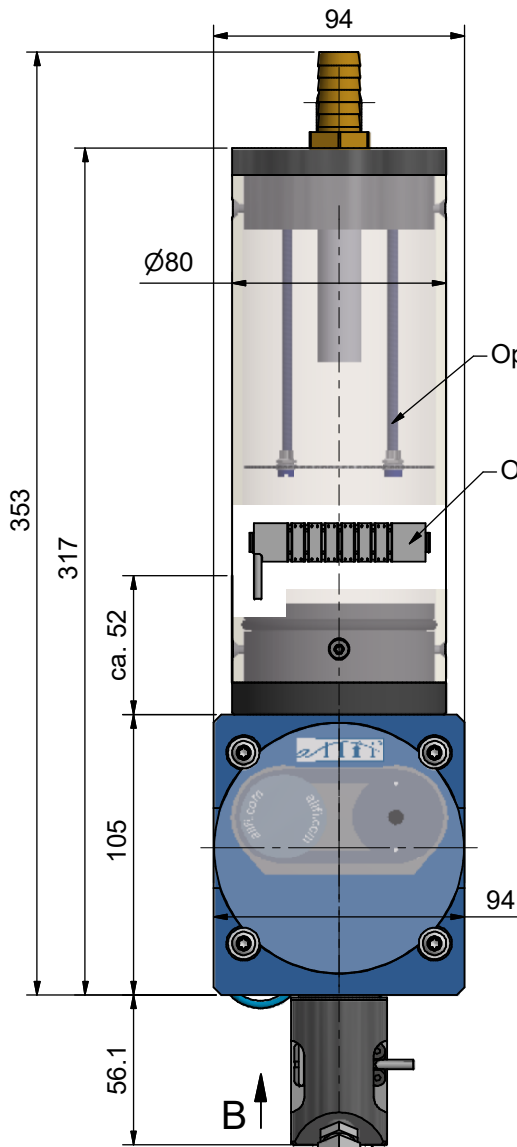

View B ( 1 : 2 )

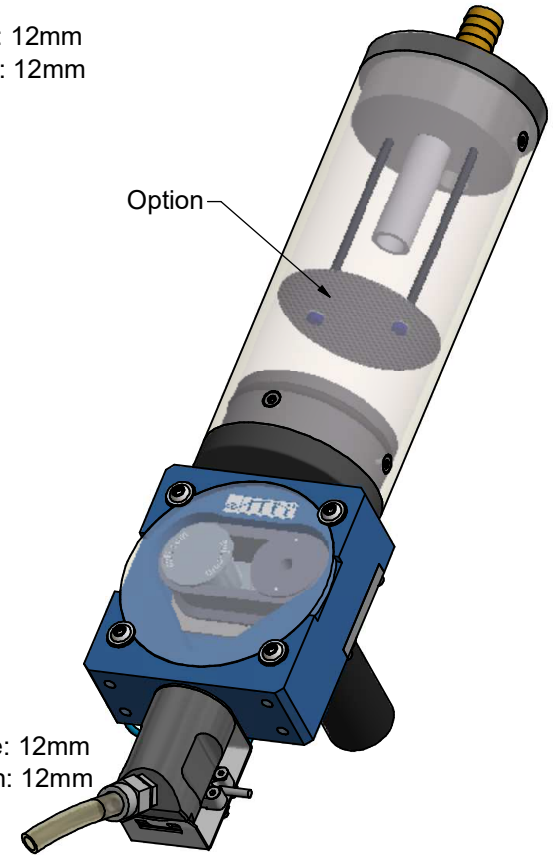
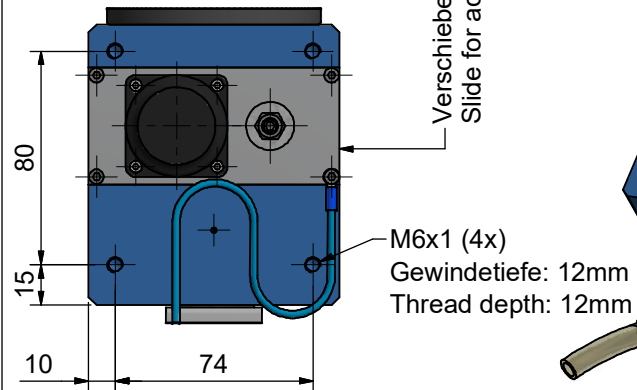
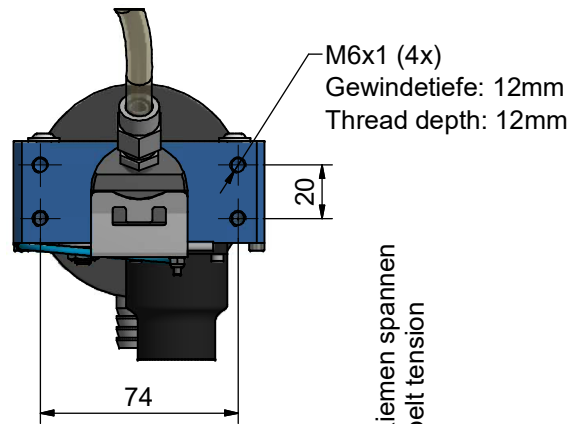

Einfache Demontage für Reinigung  
Easy removal for cleaning

Ø-Inside: 6,4mm

Drawn with all options  
Gezeichnet mit allen Optionen

General tolerances ISO 2768-1 m Designs and drawings created and produced by the contractor are the contractor's intellectual property and may only be used for the purposes of the order. Weight 2.80 kg

Amendment:	Replace for	-
A) Housing simplified, options redesigned, assembly pos. 6 new, 09.04.2019 AM	Replaced by	-
B) Schlauch/Hose was 040031, 29.09.2021 AM	Drawn	06.04.2018 AM
C) Pos 7 was 040032, 08.11.2021 AM	Checked	29.04.2019 BT
	Release	24.09.2019 RB
	Index-release	08.11.2021 RB

Abrasive Feeder / Abrasivdosierung 2.0

Scale  
//



ALLFI AG - RIEDENMATT 1 - CH-6370 STANS  
PHONE +41(0)41-618 05 05  
E-MAIL: sales@allfi.com

http://www.allfi.com

951400

Index	Sheet- No.	2
C	No. of sheets	2