

Spare Part-Set Swivel Joint 90° f/f
Article-Nr. 890052-P
Consists of 2,3,4,5,7 & 8

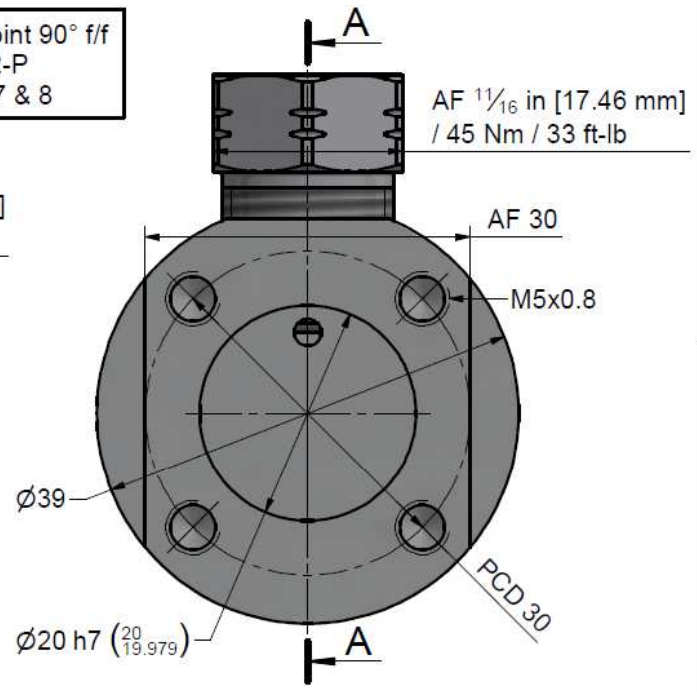

Assembling - Maintenance

This drawing is appendix A of the installation and maintenance manual "Swivel Joint 90° f/f 1/4" 2.0 Imp".
Complete installation and maintenance instruction refer to QR-Code or:
<https://www.allfi.com/en/services/downloads/product-manuals/>

- Pressure relief holes may not be covered or closed.
- Make sure that the HP Tubes are connected stress-free, i.e. do not exert any forces on the shaft.

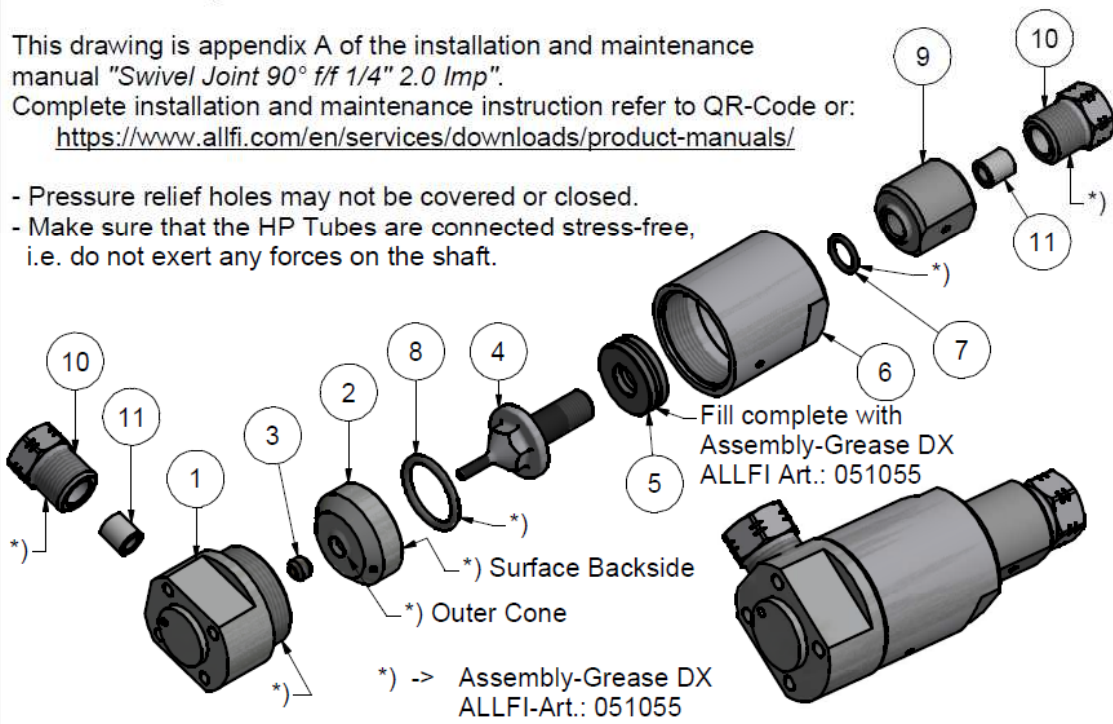

Item	Qty	Description	Part-Number	Comments	Weight
1	1	Cover 90° Angle 2.0 Imp	921601-I-P	Wear part	192.8 g
2	1	Pressure Plate 2.0	921002-P	Wear part	58.4 g
3	1	HP-Seal 2.0	912052	Wear part	1 g
4	1	Shaft for Swivel Joint f 2.0	921603-P	Wear part	35.6 g
5	1	Needle bearing	022016	Wear part	2.7 g
6	1	Casing f 2.0	921602-P		173.1 g
7	1	O-Ring D=9.52 x 1.78	010050	Wear part	0.1 g
8	1	O-Ring D=20.63 x 2.62	010145	Wear part	0.4 g
9	1	Sleeve M10 - 5/8"	921604-I-P		51.1 g
10	2	Gland Nut 1/4" Imp	701407-I-P		30.3 g
11	2	Collar 1/4"	711403		3.1 g

General tolerances ISO 2768-1 m Designs and drawings created and produced by the contractor are the contractor's intellectual property and may only be used for the purposes of the order. Weight 0.58 kg

Amendment:	Replace for	-
	Replaced by	-
	Drawn	08.04.2021 AM
Swivel Joint 90° f/f 1/4" 2.0 Imp	Scale	2 : 1
	Checked	22.06.2021 BT
	Release	29.06.2021 RB
	Index-release	

allfi
Components

ALLFI AG - RIEDENMATT 1 - CH-6370 STANS
PHONE +41(0)41-618 05 05
E-MAIL: sales@allfi.com <http://www.allfi.com>

Max. 6200 bar / 90,000 psi

921600-I-P	Index	-	Sheet-No.	2
			No. of sheets	2