

Assembling - Maintenance

This drawing is appendix A of the installation and maintenance instruction "Swivel Joint angle 6200 bar 2.0".

The complete installation and maintenance instruction is hosted at: www.allfi.com

- Pressure relief holes must not be covered or closed
- Make sure that the HP tubes are connected stress-free, i.e. do not exert any forces on the shaft.

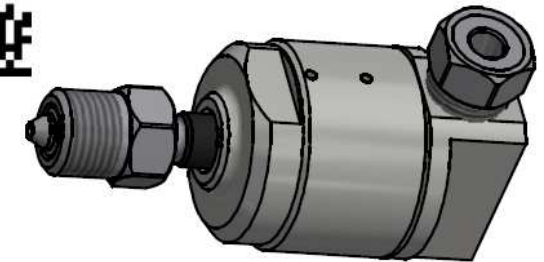

Spare Part-Set Swivel 2.0 short 6200 bar
Article-Nr. 890051-P
Consists of 2,3,4,5,7 & 10

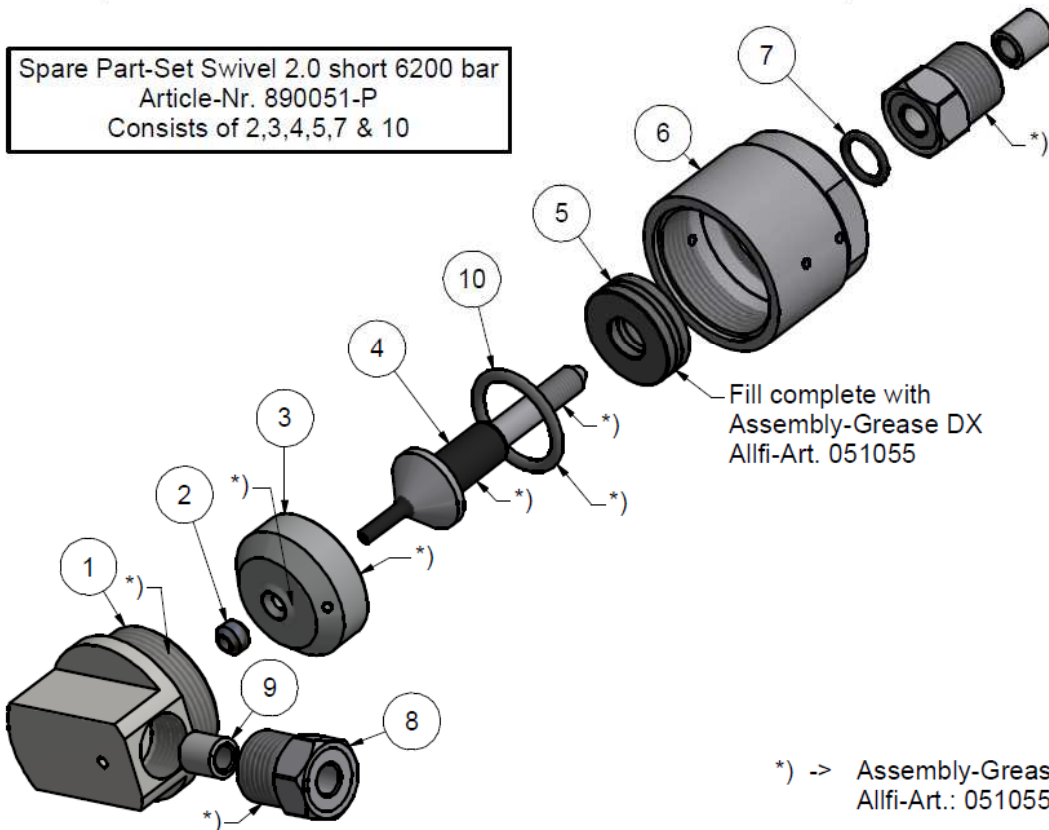

*) -> Assembly-Grease DX
Allfi-Art.: 051055

Item	Qty	Description	Part-Number	Comments	Weight
1	1	Cover 90° Angle 2.0	921315-P	Wear part	166.2 g
2	1	HP-Seal 2.0	912052	Wear part	1 g
3	1	Pressure Plate 2.0	921002-P	Wear part	58.4 g
4	1	Shaft for Swivel joint	921313-P	Wear part	30.7 g
5	1	Needle bearing	022016	Wear part	2.7 g
6	1	Casing for Swivel joint	921314		140.9 g
7	1	O-Ring D=9.52 x 1.78	010050	Wear part	0.1 g
8	2	Gland Nut 1/4" 90.000psi	701403-P		27.9 g
9	2	Collar 1/4"	711403		3.1 g
10	1	O-Ring D=20.63 x 2.62	010145	Wear part	0.4 g

General tolerances ISO 2768-1 m Designs and drawings created and produced by the contractor are the contractor's intellectual property and may only be used for the purposes of the order. Weight 0.46 kg

Amendment: A) 0066, Pos. 10 added, 18.02.2021 AM	Replace for -
	Replaced by -
Drawn 25.10.2017 AM	Checked 22.02.2018 RB
	Release 25.09.2020 RB
	Index-release 05.05.2021 BT

Swivel Joint 90° 1/4" 2.0 short

Scale
3 : 2

Max. 6200 bar / 90,000 psi

ALLFI AG - RIEDENMATT 1 - CH-6370 STANS
PHONE +41(0)41-618 05 05
E-MAIL: sales@allfi.com <http://www.allfi.com>

921300-P

Index	Sheet- No.	2
	No. of sheets	2