

Assembling - Maintenance

This drawing is appendix A of the installation and maintenance manual "Swivel Joint 90° and Parallel 1/4" 2.0 short.

Complete installation and maintenance instruction refer to QR-Code or:

<https://www.allfi.com/en/services/downloads/product-manuals/>
 - Pressure relief holes may not be covered or closed.
 - Make sure that the HP Tubes are connected stress-free, i.e. do not exert any forces on the shaft.

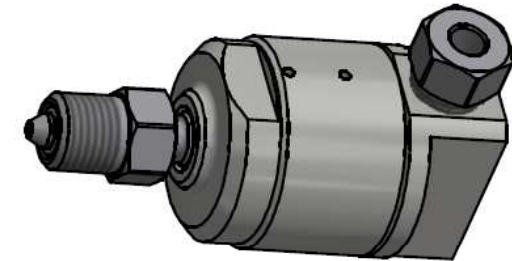

Spare Part-Set Swivel Joint 2.0 short 4150 bar
 Article-Nr. 890051
 Consists of 2,3,4,5 & 10

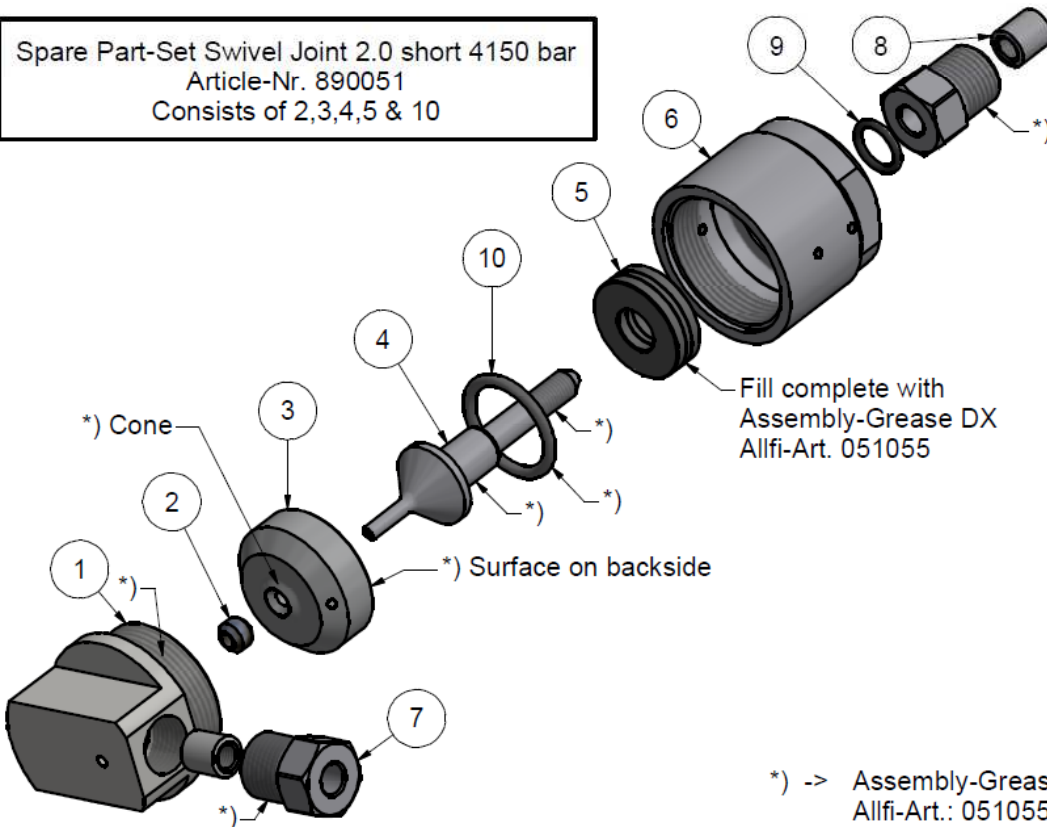

Item	Qty	Description	Part-Number	Comments	Weight
1	1	Cover 90° Angle 2.0 Imp	921315-I	Wear part	21.7 g
2	1	HP-Seal 2.0	912052	Wear part	1 g
3	1	Pressure Plate 2.0	921002-P	Wear part	58.4 g
4	1	Shaft for Swivel joint	921313	Wear part	27.2 g
5	1	Needle bearing	022016	Wear part	2.7 g
6	1	Casing for Swivel joint	921314		140.9 g
7	2	Gland Nut 1/4" Imp	701407		22.8 g
8	2	Collar 1/4"	711403		3.1 g
9	1	O-Ring D=9.52 x 1.78	010050	Wear part	0.1 g
10	1	O-Ring D=20.63 x 2.62	010145	Wear part	0.4 g

General tolerances ISO 2768-1 m Designs and drawings created and produced by the contractor are the contractor's intellectual property and may only be used for the purposes of the order. Weight 0,30 kg

Amendment:	Replace for:	-
	Replaced by:	-
	Drawn:	02.04.2024 PH
	Checked:	17.04.2024 AM
	Release:	17.04.2024 PH
	Index-release:	

Swivel Joint 90° 1/4" 2.0 short Imp Scale 3 : 2

Max. 4150 bar / 60,000 psi

	ALLFI AG - RIEDENMATT 1 - CH-6370 STANS PHONE +41(0)41-618 05 05 E-MAIL: sales@allfi.com	http://www.allfi.com	Index	Sheet-	2
			921300-I	No. of sheets	2