

## Assembling - Maintenance

This drawing is appendix A of the installation and maintenance instruction "Pressure release valve 3/8\"". The complete installation and maintenance instruction is hosted at [www.allfi.com](http://www.allfi.com)

- Can be used as shut-off valve
- Pneumatic cylinder **must not** be pressurized during assembly & disassembly
- Function test with several open and closed cycles
- After finishing maintenance flush the valve at < 500 bar / 7'200 psi
- Pressure relief holes must not be covered or closed

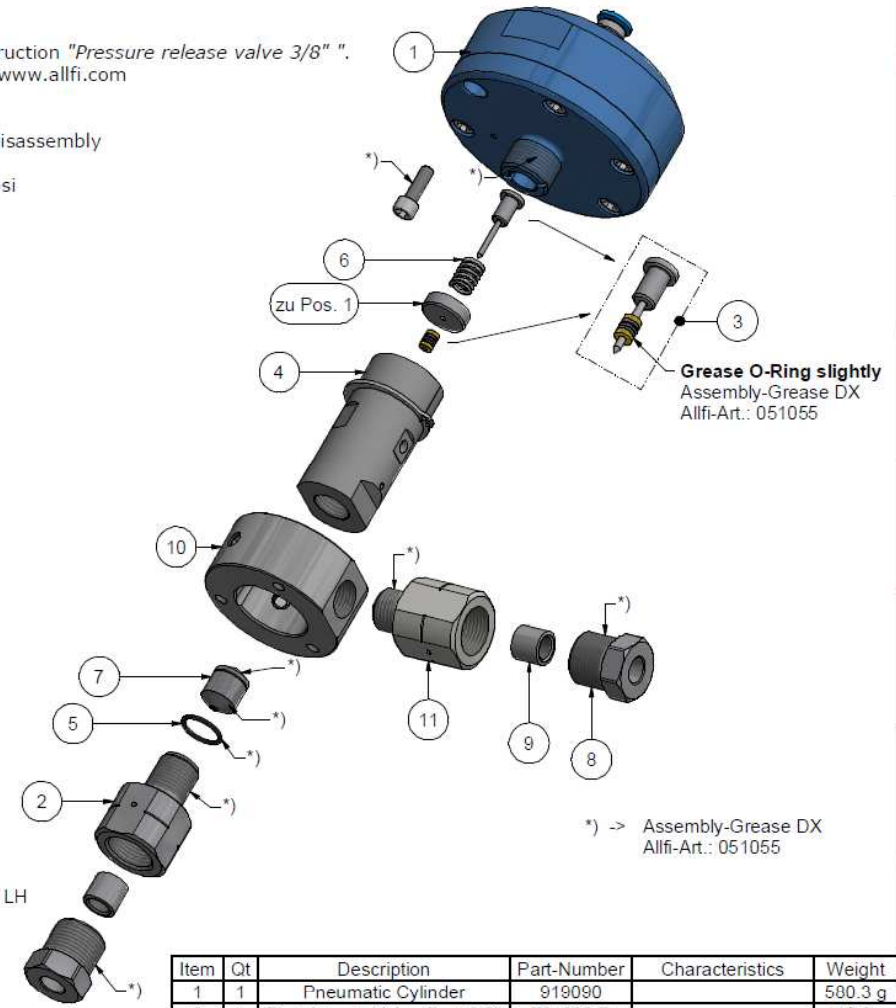
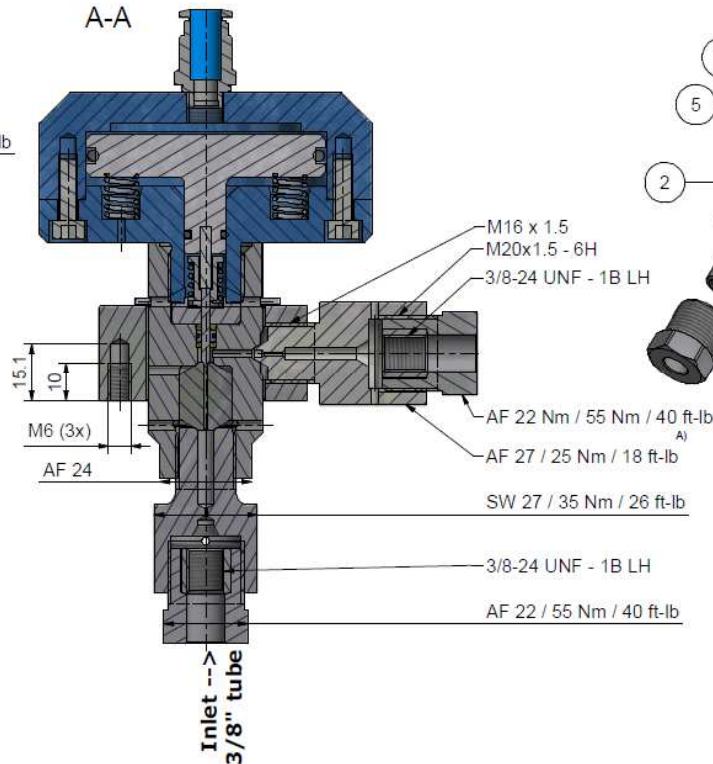
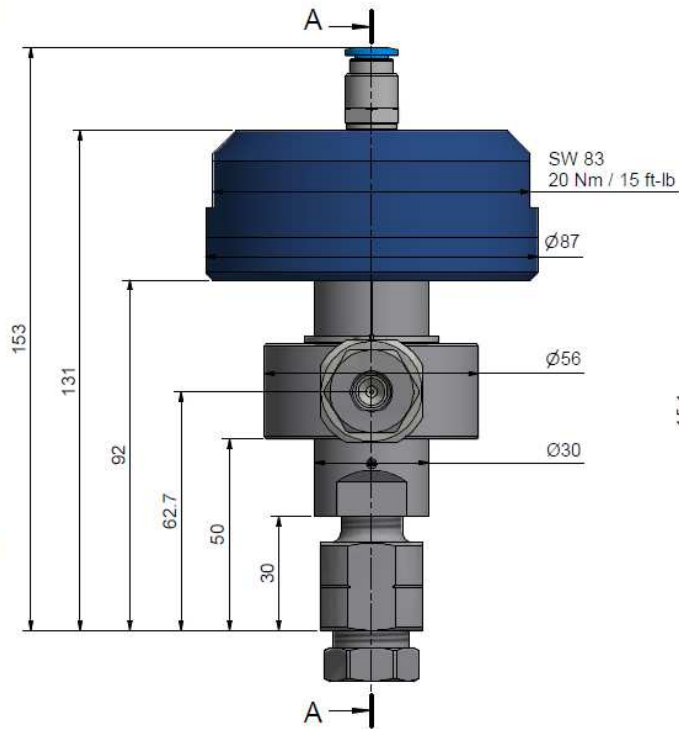
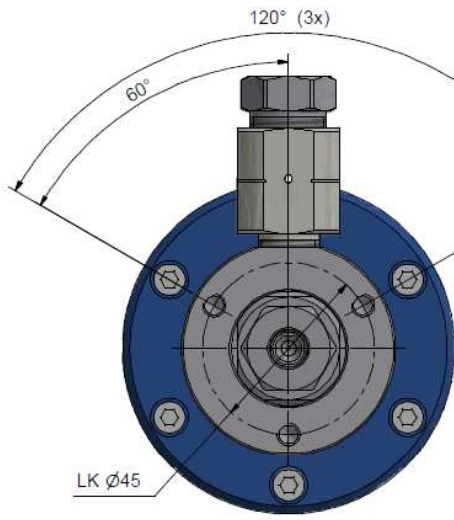

Item	Qt	Description	Part-Number	Characteristics	Weight
1	1	Pneumatic Cylinder	919090		580.3 g
2	1	Restrictor to Valve Seat 3/8"	901260-P		112.9 g
3	1	Seal kit	901431	Wear part	3.6 g
4	1	Valve case	900610	Wear part	245.8 g
5	1	O-Ring D=14 x 1.5	010013		0.1 g
6	1	Compression Spring	021006		1.4 g
7	1	Valve Seat	900014	Wear part	17.2 g
8	2	Gland Nut 3/8"	703800		48.1 g
9	2	Collar 3/8"	713800		6.8 g
10	1	Coupling Ring	900074		305.8 g
11	1	Restrictor m/f 1/4" - 3/8"	661438-P	Wear part	130.2 g

General tolerances ISO 2768-1 m Designs and drawings created and produced by the contractor are the contractor's intellectual property and may only be used for the purposes of the order.

Amendment:	Replace for:	-
A) 0058, Drehmoment angepasst, 14.02.2020	Replaced by:	-
	Drawn:	18.04.2017 AM
	Checked:	19.04.2017 RB
	Release:	19.04.2017 BT
	Index-release:	24.02.2020 BT

Pressure relief valve 3/8"

Scale  
1 : 1

Max. 4150 bar / 60,000 psi



ALLFI AG - RIEDENMATT 1 - CH-6370 STANS  
PHONE +41(0)41-618 05 05 - TELEFAX +41(0)41-618 05 10  
E-MAIL: [sales@allfi.com](mailto:sales@allfi.com) <http://www.allfi.com>

919110

Index Sheet-  
No. of  
sheets 2