

Assembling - Maintenance

This drawing is appendix A of the installation and maintenance instruction "Pressure release valve 3/8" ". The complete installation and maintenance instruction is hosted at www.allfi.com

- Can be used as shut-off valve
- Pneumatic cylinder **must not** be pressurized during assembly & disassembly
- Function test with several open and closed cycles
- After finishing maintenance flush the valve at < 500 bar / 7'200 psi
- Pressure relief holes must not be covered or closed

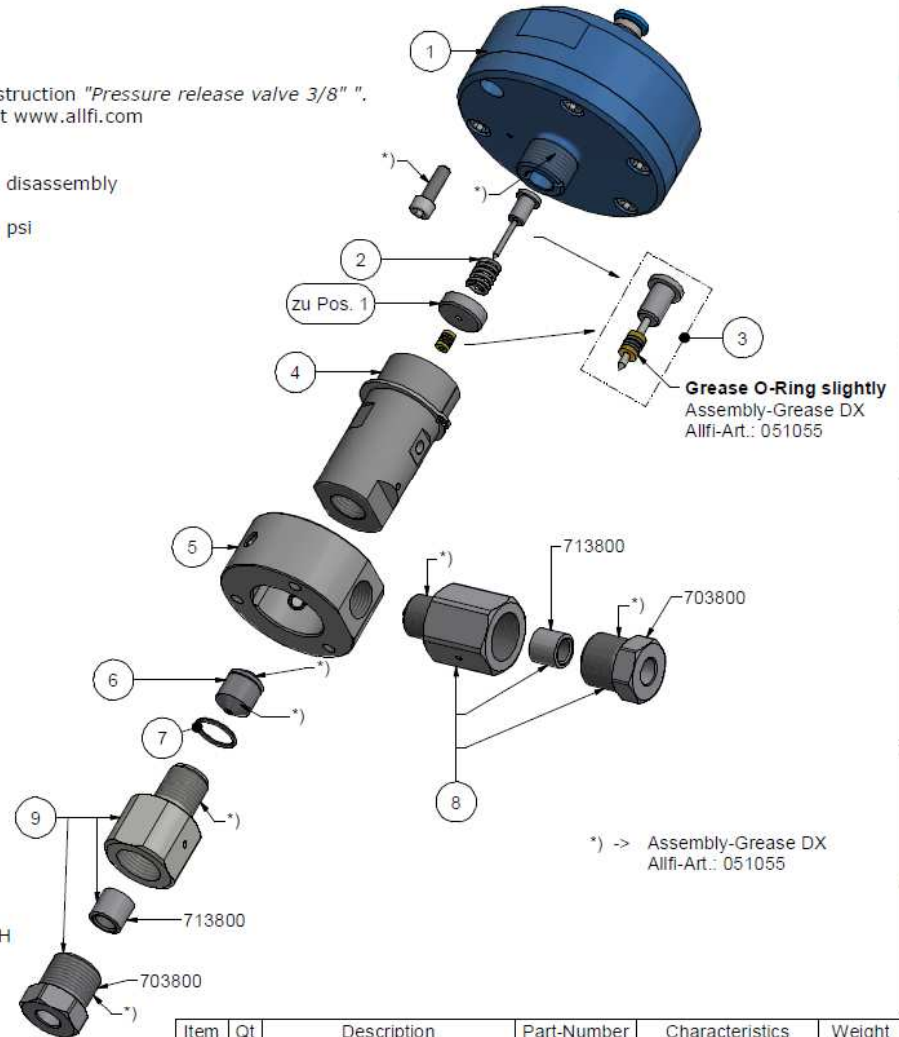
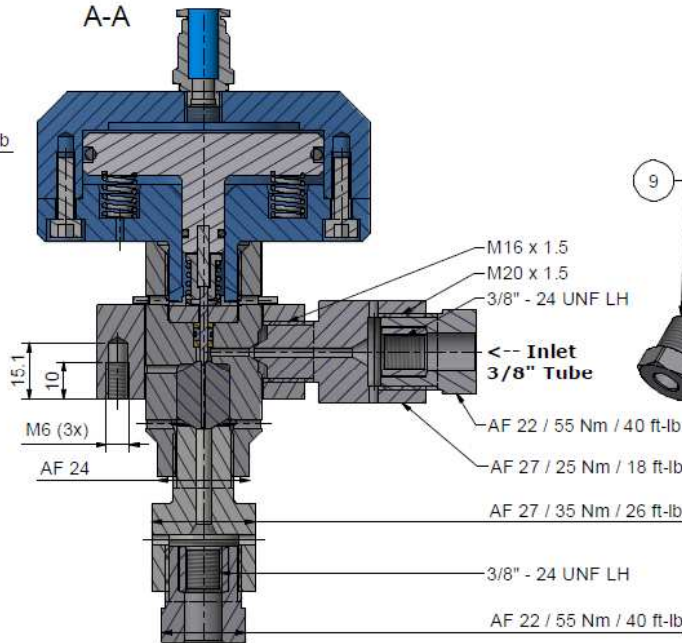
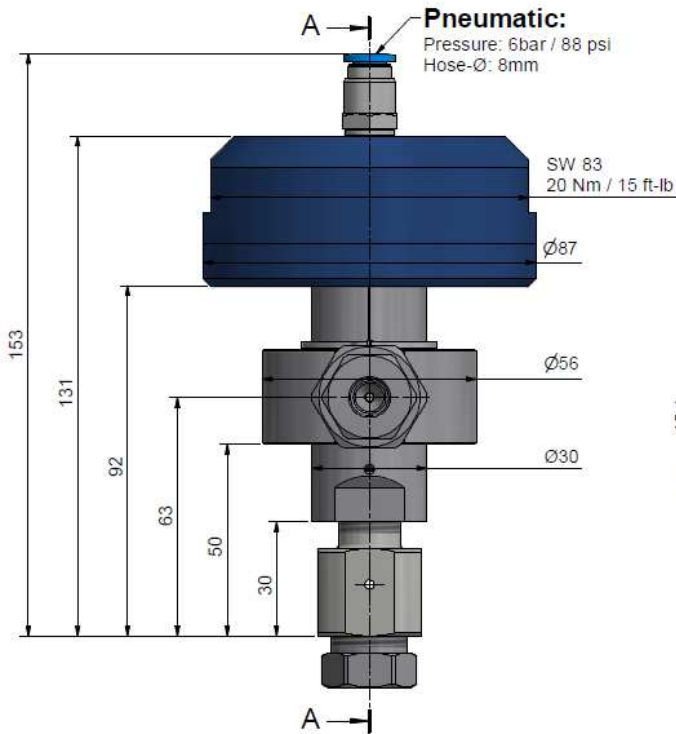

Item	Qt	Description	Part-Number	Characteristics	Weight
1	1	Pneumatic Cylinder	919090		580.3 g
2	1	Compression Spring	021006		1.4 g
3	1	Seal kit	901431 ^{g)}	Wear part	3.6 g
4	1	Valve case	900610	Wear part	245.8 g
5	1	Coupling Ring	900074		305.8 g
6	1	Valve Seat	900014	Wear part	17.2 g
7	1	O-Ring D=14 x 1.5	010013		0.1 g
8	1	Reducer m/f 1/4" - 3/8"	651438	Wear part	182.8 g
9	1	Adapter 3/8" to Valve Case	901255	Wear part	168.2 g

General tolerances ISO 2768-1 mK		Designs and drawings created and produced by the contractor are the contractor's intellectual property and may only be used for the purposes of the order.	
Amendment:		Replace for:	-
3) neue Zeichnung erstellt, 29.08.2011 st		Replaced by:	-
f) Beschreibung neu definiert, 13.08.2017 AH		Drawn:	29.08.2011 sl
g) 0029, Zeichsatz war 001430, 04.10.2017 AH		Checked:	29.08.2011 sl
		Release:	01.12.2009 BM
		Index-release:	16.10.2017 RB

Pressure relief valve 3/8"

Scale: 1 : 1

Max. 4150 bar / 60,000 psi
Normally open

919100

ALLFI AG - RIEDENMATT 1 - CH-8370 STANS
PHONE +41(0)41-818 05 05
E-MAIL: sales@allfi.com <http://www.allfi.com>

Index	Sheet-
G	No. 2
	No. of sheets
	2