

Assembling - Maintenance

This drawing is appendix A of the installation and maintenance instruction "Pressure release valve 2.0".
Complete installation and maintenance instruction refer to QR-Code or:
<https://www.allfi.com/en/services/downloads/product-manuals/>

- Pneumatic cylinder **must not** be pressurized during assembly & disassembly.
- Function test with several open and closed cycles.
- Pressure relief holes must not be covered or closed.



Detail X (5 : 1)

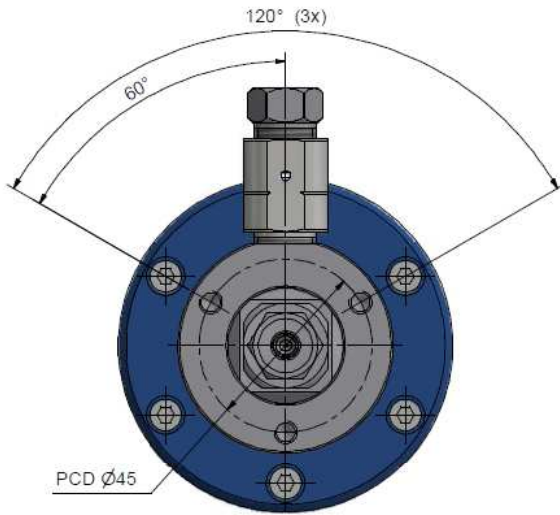
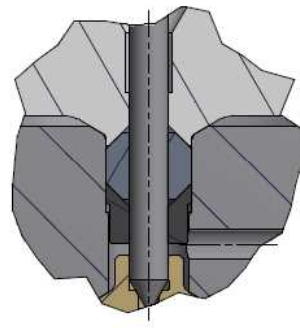

Pneumatic

Hose-Ø: 8 mm
Pressure: 6 - 7 bar / 87 - 102 psi

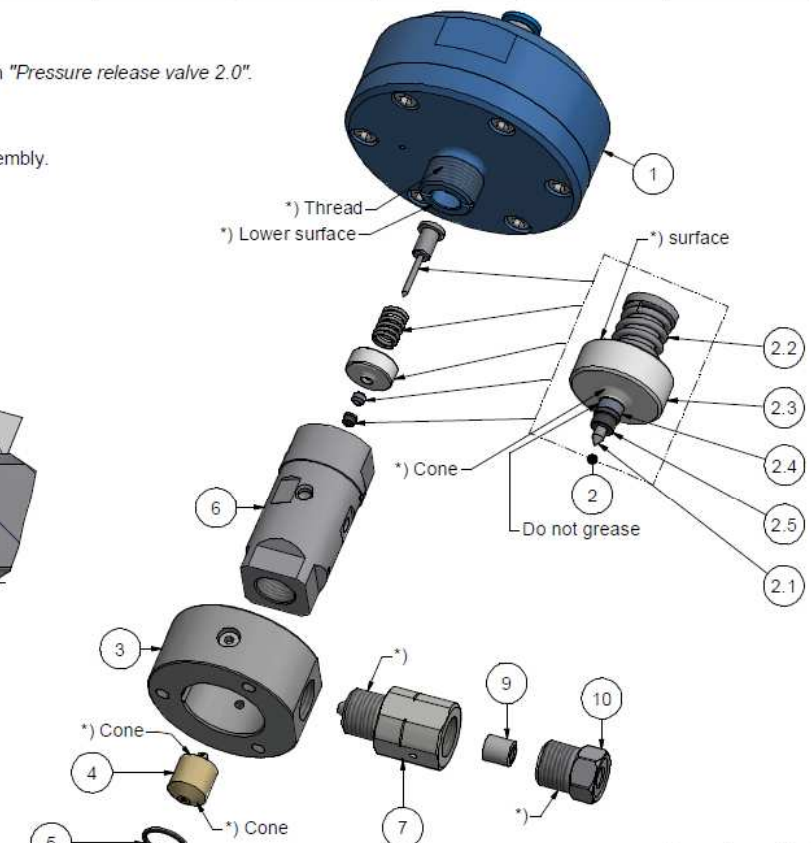
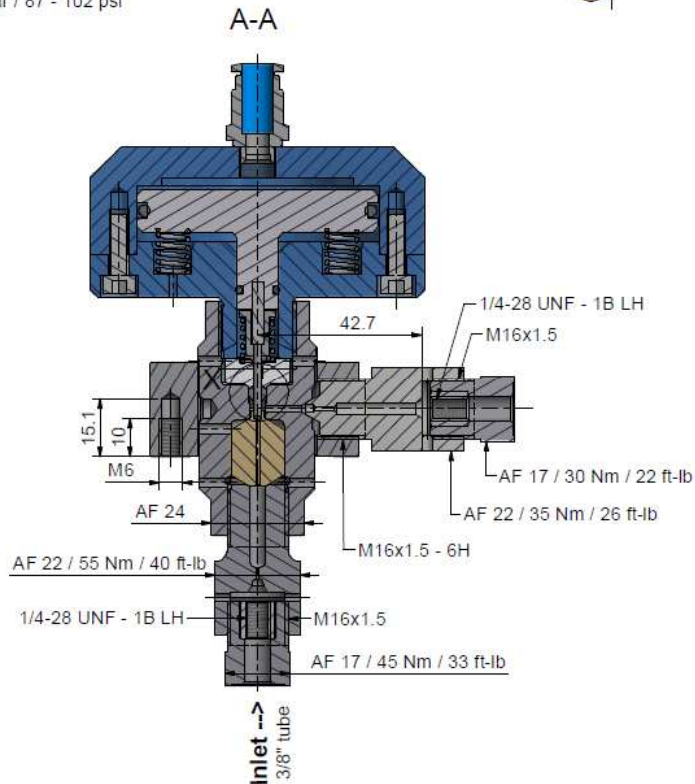
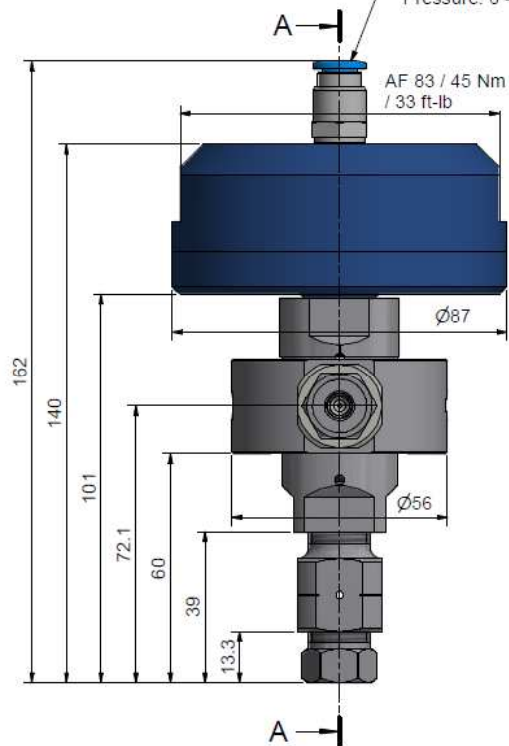

*) -> Assembly-Grease DX
Allfi-Art.: 051055

Item	Qty	Description	Part-Number	Comments	Weight
1	1	Pneumatic Cylinder 2.0	919095		570.2 g
2	1	Seal Kit 2.0 Pressure relief valve	919014-P	Wear part	15.8 g
2.1	1	Valve needle	901416		3.1 g
2.2	1	Compression Spring	021006		1.4 g
2.3	1	Pressure plate 3.0	908023		11 g
2.4	1	HP-seal 2.0 short	900632		0.1 g
2.5	1	Conus disc 2.0	901439		0.2 g
3	1	Coupling ring Typ 2.0	900132		306.6 g
4	1	Valve seat 2.0 for PRV	919019	Wear part	17.5 g
5	1	O-Ring D=14 x 1.5	010013		0.1 g
6	1	Valve Case 2.0	900624-P	Wear part	236.1 g
7	1	Restrictor m/f 1/4" - 1/4"	661414-P	Wear part	85.5 g
8	1	Restrictor to Valve Seat 1/4"	901261-P	Wear part	79.8 g
9	2	Collar 1/4"	711403		3.1 g
10	2	Gland Nut 1/4" 90.000psi	701403-P		27.9 g

General tolerances ISO 2768-1 mK Designs and drawings created and produced by the contractor are the contractor's intellectual property and may only be used for the purposes of the order.

Amendment:	Replace for -
	Replaced by -
	Drawn 20.04.2023 AM
	Checked 26.08.2024 BT
	Release 17.10.2024 PH
	Index-release

Pressure relief valve 1/4" 2.0

Scale 1 : 1
Max. 6200 bar / 90,000 psi

allfi Components
ALLFI AG - RIEDENMATT 1 - CH-8370 STANS
PHONE +41(0)41-818 05 05
E-MAIL: sales@allfi.com <http://www.allfi.com>

919015-P

Index	Sheet No.	2
-	No. of sheets	2