

Assembling - Maintenance

This drawing is appendix A of the installation and maintenance manual "HP-check valve 3/8" 2.0". Complete installation and maintenance instruction refer to QR-Code or: <https://www.allfi.com/en/services/downloads/product-manuals/>

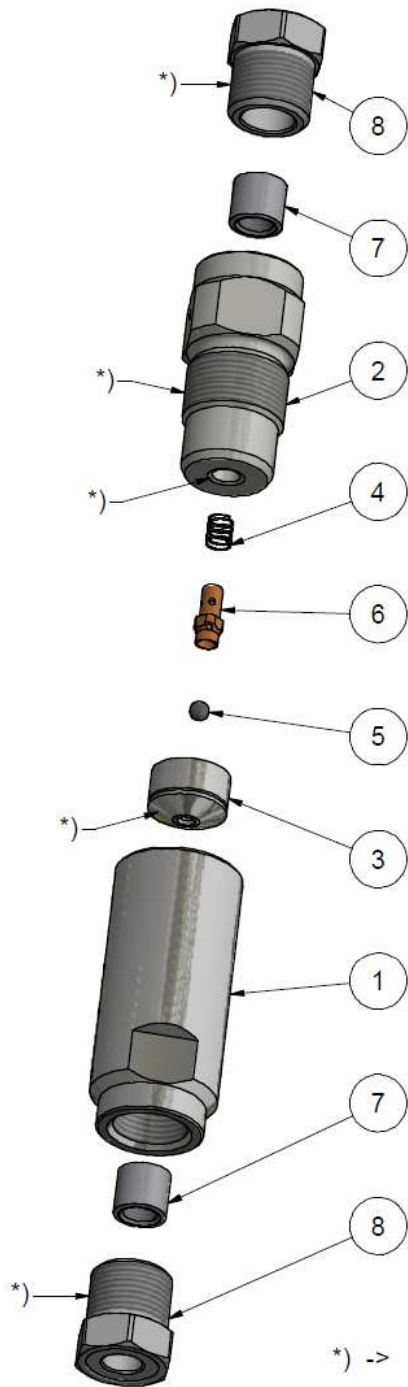

- Pressure relief holes may not be covered or closed.

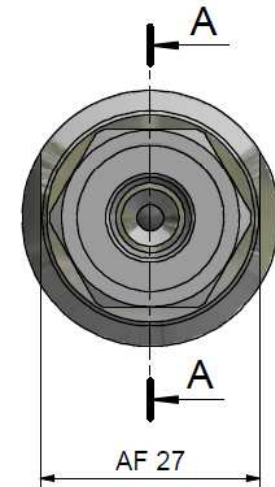
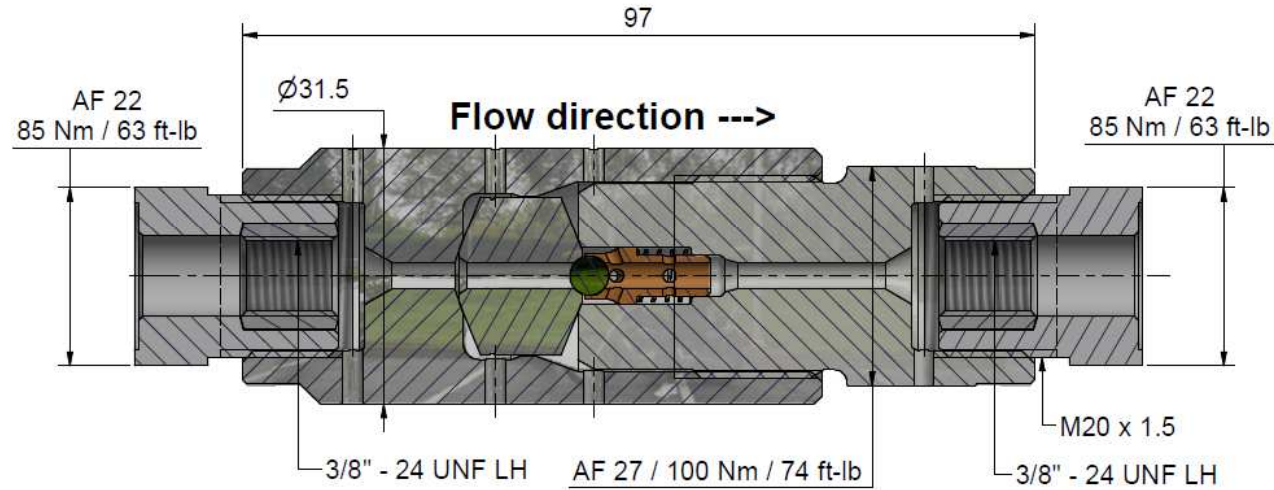

*) -> Assembly-Grease DX
ALLFI-Art.: 051055

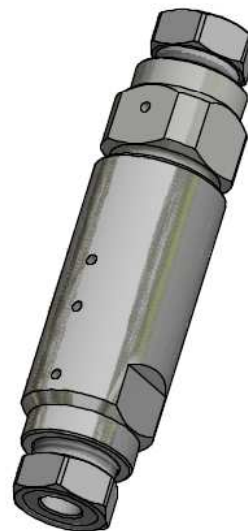

Item	Qty	Description	Part-Number	Comments	Weight
1	1	Case 3/8"	918111-P	Wear part	240.4 g
2	1	Lock screw 3/8"	918112-P	Wear part	189.3 g
3	1	Valve Seat 3/8"	918113-P	Wear part	27.5 g
4	1	Spring	021042	Wear part	0.1 g
5	1	Sphere	A0227-02	Wear part	0.2 g
6	1	Sphere guide 3/8"	918114-P	Wear part	1.8 g
7	2	Collar 3/8"	713800		6.8 g
8	2	Gland Nut 3/8"	703800-P		46.1 g

General tolerances ISO 2768-1 mK Designs and drawings created and produced by the contractor are the contractor's intellectual property and may only be used for the purposes of the order. Weight 0,56 kg

Amendment:		Replace for	-
		Replaced by	-
		Drawn	16.01.2023 AM
HP-check valve 3/8" 2.0		Scale	3 : 2
		Checked	03.07.2023 BT
		Release	03.07.2023 BT
		Index-release	

allfi
Components

ALLFI AG - RIEDENMATT 1 - CH-6370 STANS
PHONE +41(0)41-618 05 05 - TELEFAX +41(0)41-618 05 10
E-MAIL: sales@allfi.com <http://www.allfi.com>

Max. 6200 bar / 90,000 psi

918110-P

Index	Sheet-	2
	No.	
	No. of	2
	sheets	