

Assembling - Maintenance

This drawing is appendix A of the installation and maintenance instruction "Hand valve 2.0".

Complete installation and maintenance instruction refer to QR-Code or:

<https://www.allfi.com/en/services/downloads/product-manuals/>

- Pressure relief holes must not be covered or closed.



Detail B (3 : 2)

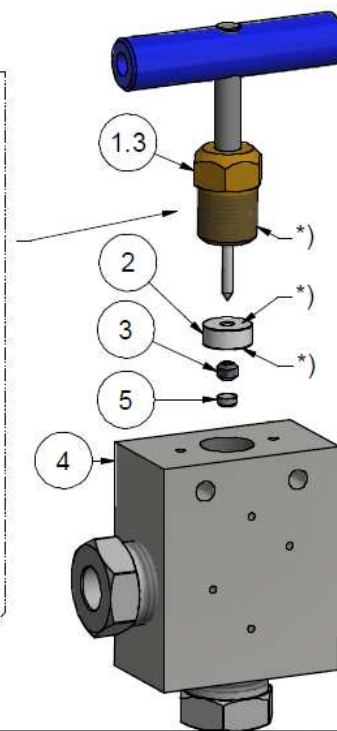
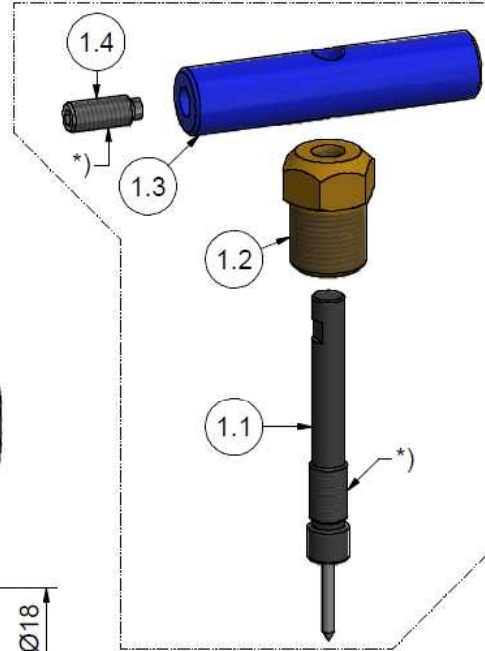
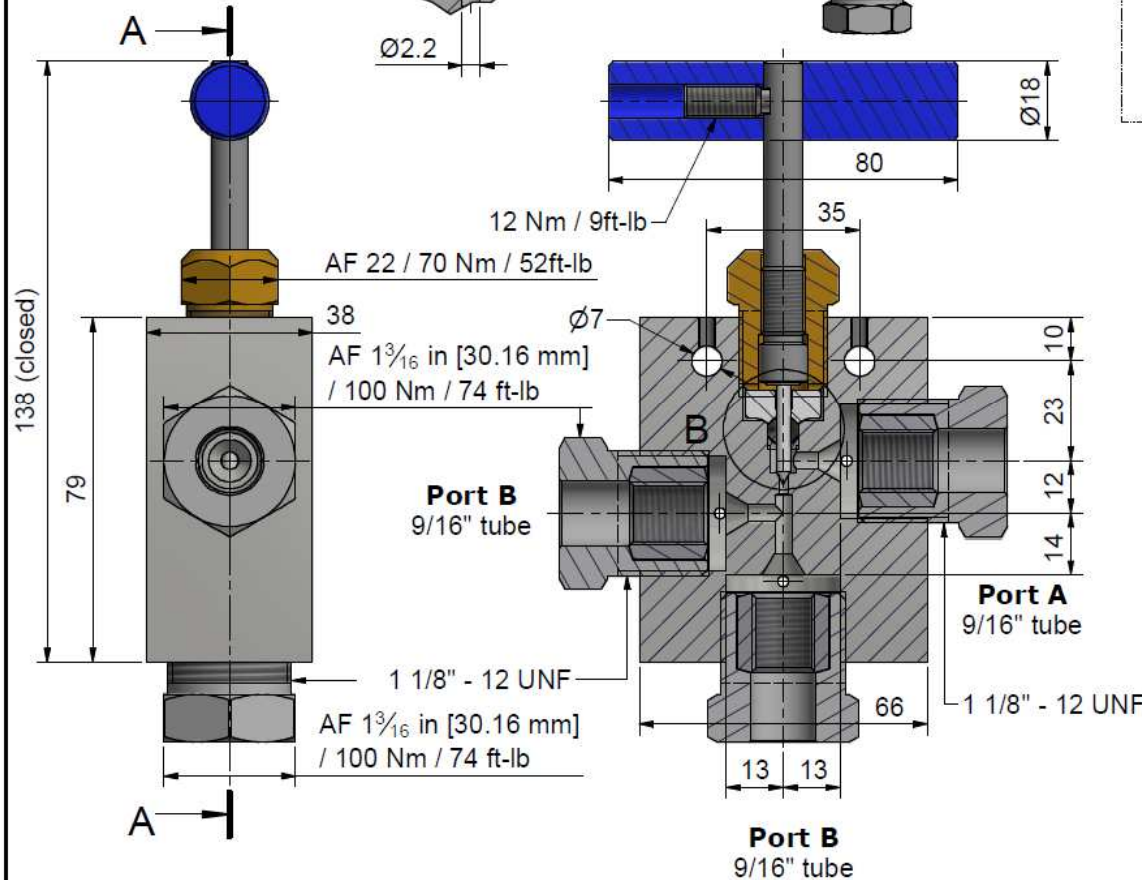
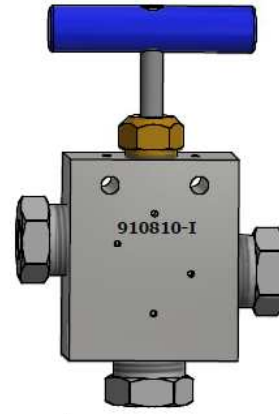
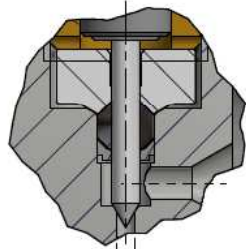

*) -> Assembly-Grease DX
Allfi-Art.: 051055

Sealing kit 2.0
912077
Including Pos.
1.1, 2, 3, 5

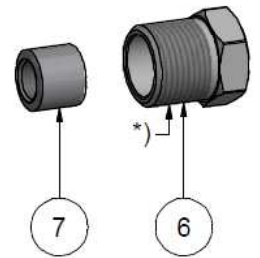

Item	Qty	Description	Part-Number	Comments	Weight
1	1	Spindle complete 2.0	910062		169.9 g
1.1	1	Needle with spindle 2.0	912059	Wear part	39.9 g
1.2	1	Clamp Handle 2.0	912057		48.2 g
1.3	1	Spindle Nut 2.0	912058		75.1 g
1.4	1	Screw	000044		6.7 g
2	1	Pressure plate 2.0	912053	Wear part	11.8 g
3	1	HP-Seal 2.0	912052	Wear part	1 g
4	1	Valve Body 3-Way 9/16" 2.0 Imp	912071-I	Wear part	1206.1 g
5	1	Conical disc 2.0	912062	Wear part	0.4 g
6	3	Gland Nut 9/16" Imp	709107		14.1 g
7	3	Collar 9/16"	719100		28.9 g

General tolerances ISO 2768-1 m Designs and drawings created and produced by the contractor are the contractor's intellectual property and may only be used for the purposes of the order.

Amendment:	Replace for	912022-I, 910800-I
	Replaced by	-
	Drawn	07.09.2016 AM
	Checked	04.05.2017 RB
	Release	12.06.2017 BT
	Index-release	

Hand Valve 3-Way 9/16" 2.0 Imp	Scale	4 : 5
---------------------------------------	-------	-------

Max 4150 bar / 60,000 psi
Hand Valve 2.0

ALLFI AG - RIEDENMATT 1 - CH-6370 STANS PHONE +41(0)41-618 05 05 - TELEFAX +41(0)41-618 05 10 E-MAIL: sales@allfi.com http://www.allfi.com	910810-I	Index	-	Sheet- No.	2
		No. of sheets	1		