

# Assembling - Maintenance

This drawing is appendix A of the installation and maintenance instruction "Hand valve 2.0".  
The complete installation and maintenance instruction is hosted at [www.allfi.com](http://www.allfi.com)

- Pressure relief holes must not be covered or closed



Detail B ( 3 : 2 )

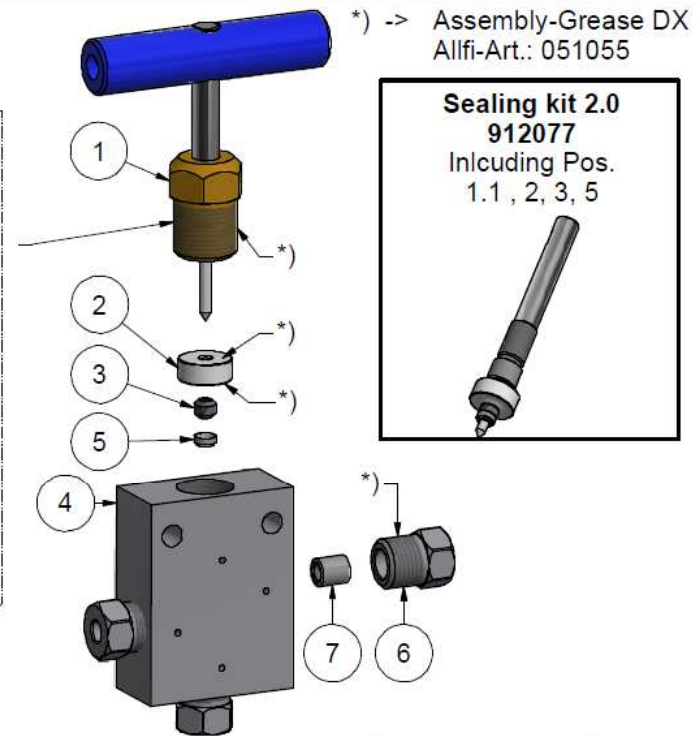
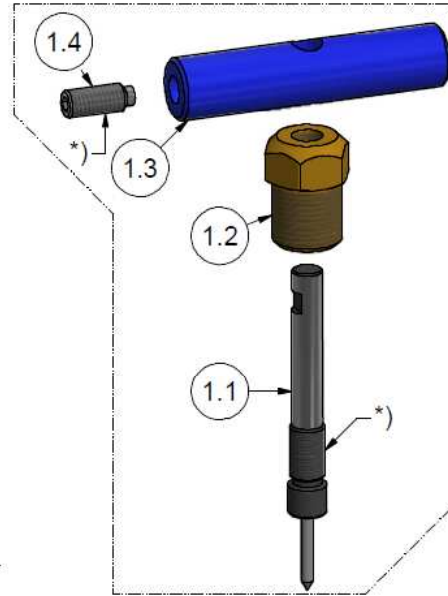
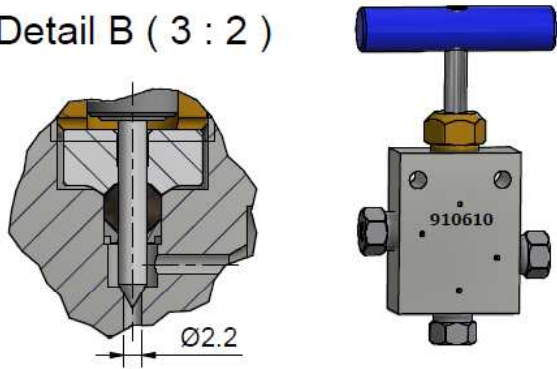

**Sealing kit 2.0  
912077**  
Including Pos.  
1.1, 2, 3, 5

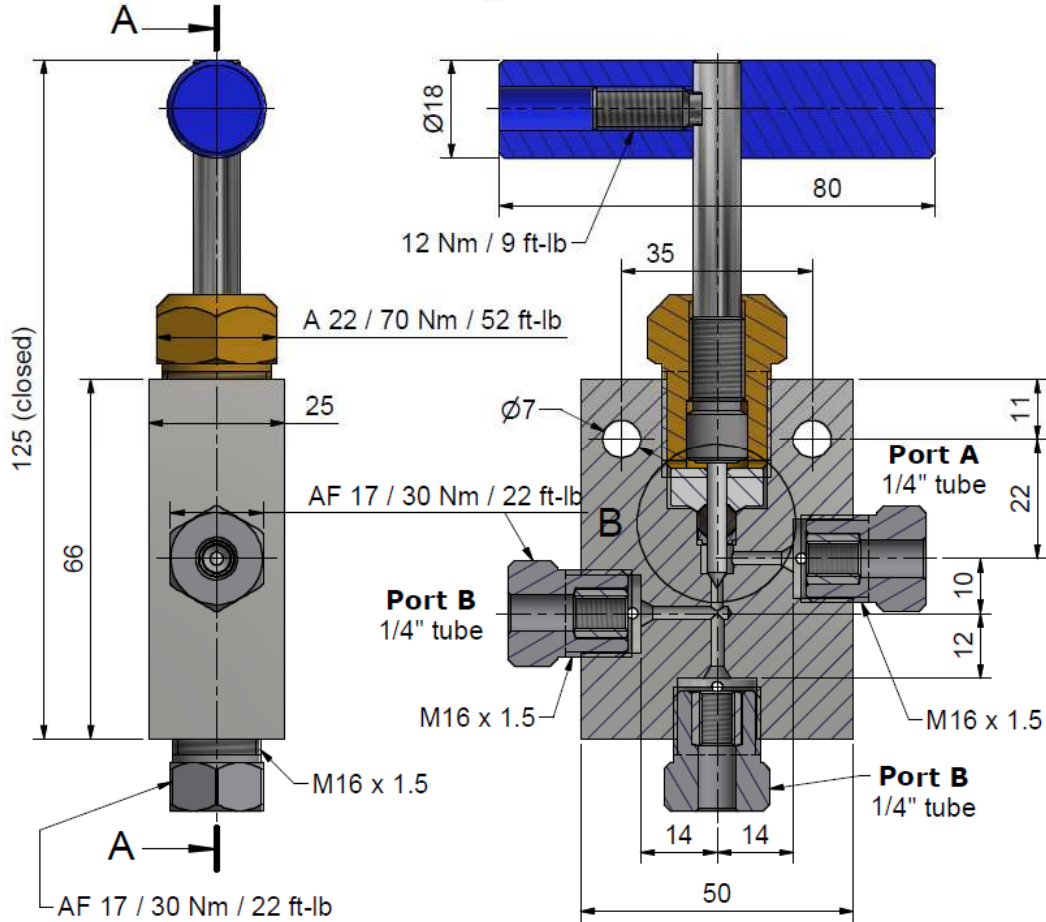

Item	Qty	Description	Part-Number	Comments	Weight
1	1	Spindle complete 2.0	910062		169.9 g
1.1	1	Needle with spindle 2.0	912059	Wear part	
1.2	1	Spindle Nut 2.0	912058		
1.3	1	Clamp Handle 2.0	912057		
1.4	1	Screw	000044		
2	1	Pressure plate 2.0	912053	Wear part	11.8 g
3	1	HP-Seal 2.0	912052	Wear part	1 g
4	1	Valve Body 3-Way 1/4" 2.0	912064	Wear part	531.4 g
5	1	Conical disc 2.0	912062	Wear part	0.4 g
6	3	Gland Nut 1/4"	701403		29.1 g
7	3	Collar 1/4"	711403		3.1 g

General tolerances ISO 2768-1 m Designs and drawings created and produced by the contractor are the contractor's intellectual property and may only be used for the purposes of the order.

Amendment:	Replace for	912002, 910600
	Replaced by	-
	Drawn	02.08.2016 AM
	Checked	02.05.2017 RB
	Release	29.05.2017 BT
	Index-release	

**Hand Valve 3-Way 1/4" 2.0**

Scale: 1 : 1

Max 4150 bar / 60,000 psi  
Hand Valve 2.0

**910610**

ALLFI AG - RIEDENMATT 1 - CH-6370 STANS  
PHONE +41(0)41-618 05 05 - TELEFAX +41(0)41-618 05 10  
E-MAIL: [sales@allfi.com](mailto:sales@allfi.com) <http://www.allfi.com>

Index	Sheet-	2
-	No. of sheets	1