

# Assembling - Maintenance

This drawing is appendix A of the installation and maintenance instruction "Pneumatic Valve 2.0". Complete installation and maintenance instruction refer to QR-Code or: <https://www.allfi.com/en/services/downloads/product-manuals/>

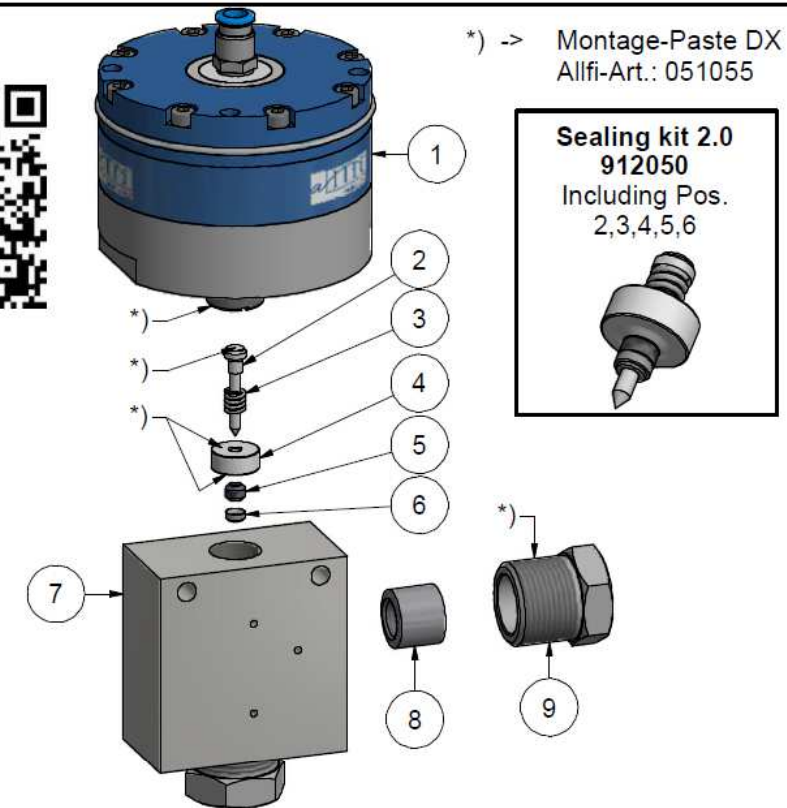

- Pressure relief holes must not be covered or closed.

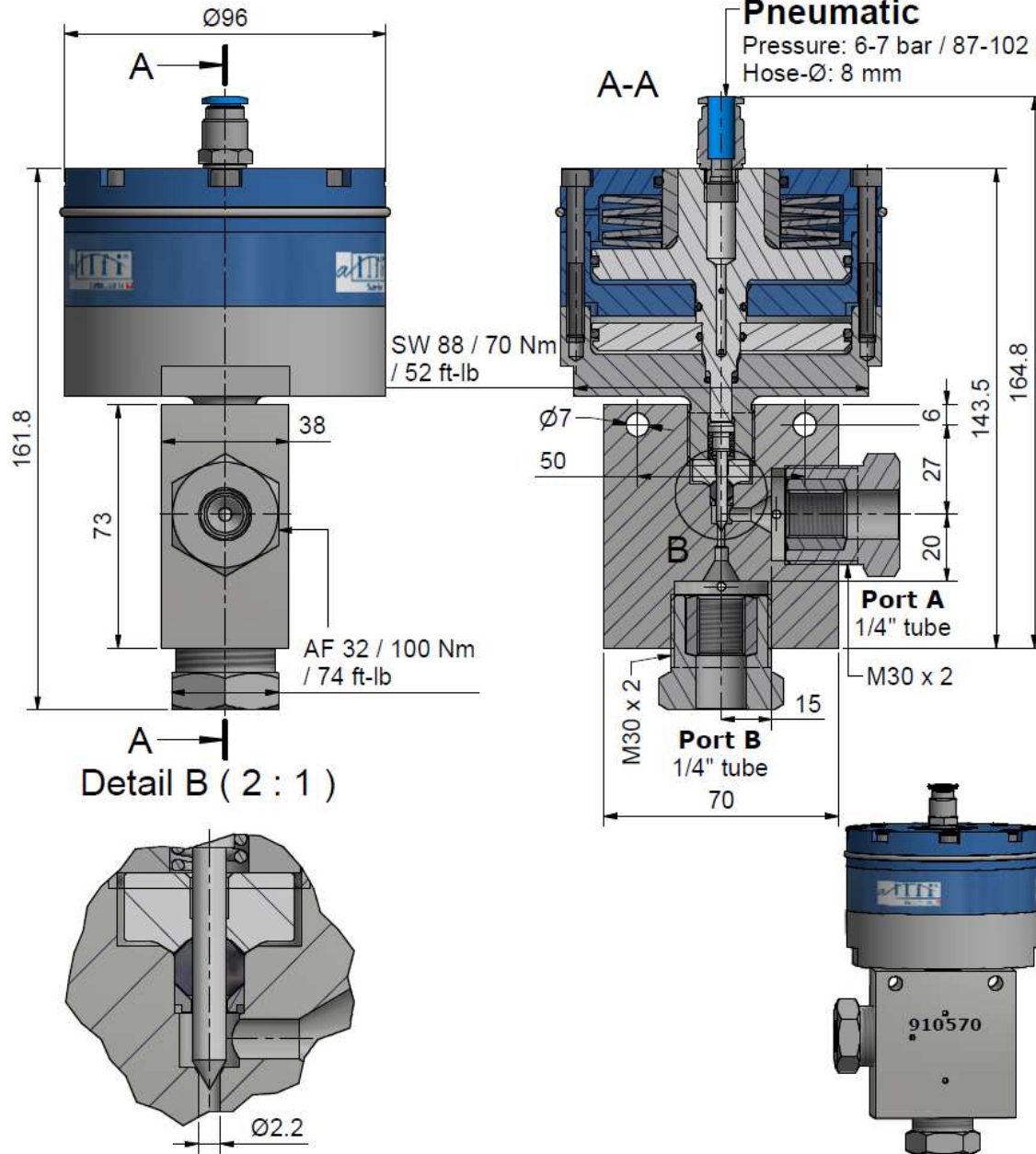

**Sealing kit 2.0**  
**912050**  
 Including Pos.  
 2,3,4,5,6

Item	Qty	Description	Part-Number	Comments	Weight
1	1	Pneumatic cylinder 2.0 NC	912190		2293.9 g
2	1	Needle complete 2.0	912076	Wear part	2.2 g
3	1	Spring	021033		0.1 g
4	1	Pressure plate 2.0	912053	Wear part	11.8 g
5	1	HP-Seal 2.0	912052	Wear part	1 g
6	1	Conical disc 2.0	912062	Wear part	0.4 g
7	1	Valve Body angle 9/16" 2.0	912074	Wear part	1242.2 g
8	2	Collar 9/16"	719100		28.9 g
9	2	Gland Nut 9/16"	709100		132.8 g

General tolerances ISO 2768-1 m Designs and drawings created and produced by the contractor are the contractor's intellectual property and may only be used for the purposes of the order.

Amendment:	Replace for	-
	Replaced by	-
	Drawn	05.04.2017 AM
	Checked	22.07.2019 RB
	Release	22.07.2019 RB
	Index-release	

**Pneum. Valve 2-Way Angle 9/16" NC 2.0**

Scale: 2 : 3

Max 4150 bar / 60,000 psi  
 Normally closed

**910570**

ALLFI AG - RIEDENMATT 1 - CH-6370 STANS  
 PHONE +41(0)41-618 05 05 - TELEFAX +41(0)41-618 05 10  
 E-MAIL: sales@allfi.com http://www.allfi.com

Index	Sheet-	2
	No.	
	No. of	2
	sheets	