

Assembling - Maintenance

This drawing is appendix A of the installation and maintenance instruction "Hand valve 2.0".

Complete installation and maintenance instruction refer to QR-Code or:
<https://www.allfi.com/en/services/downloads/product-manuals/>

- Pressure relief holes must not be covered or closed.



Detail B

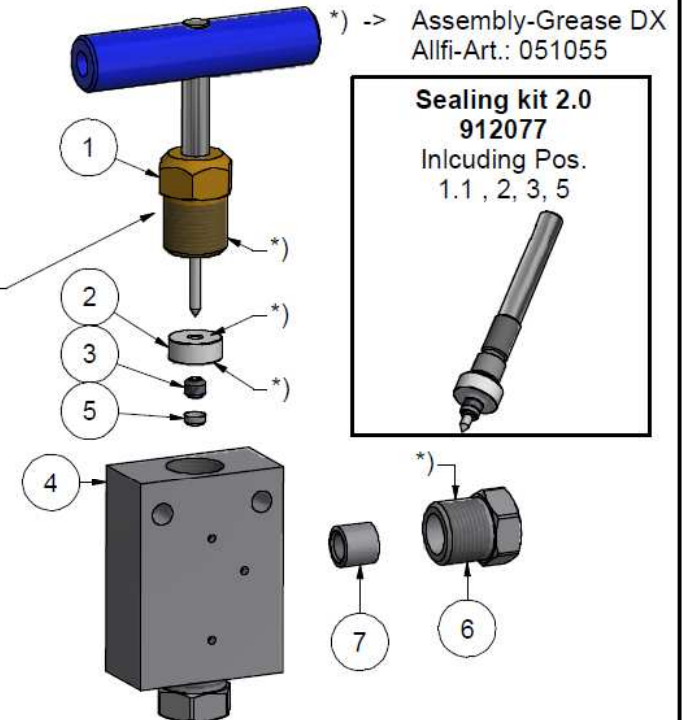
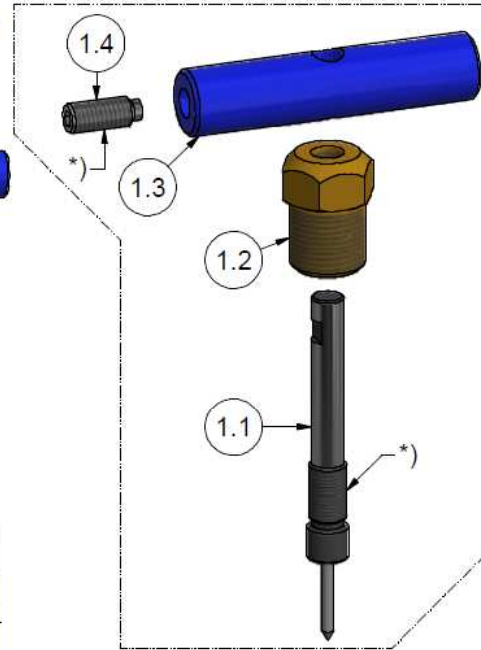
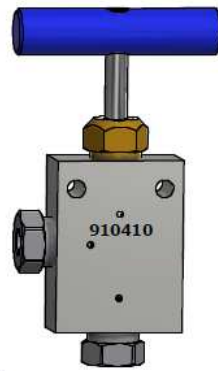
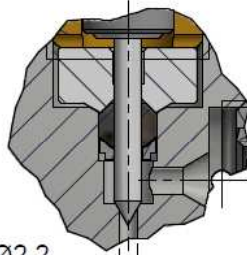

Sealing kit 2.0
912077
 Including Pos.
 1.1, 2, 3, 5

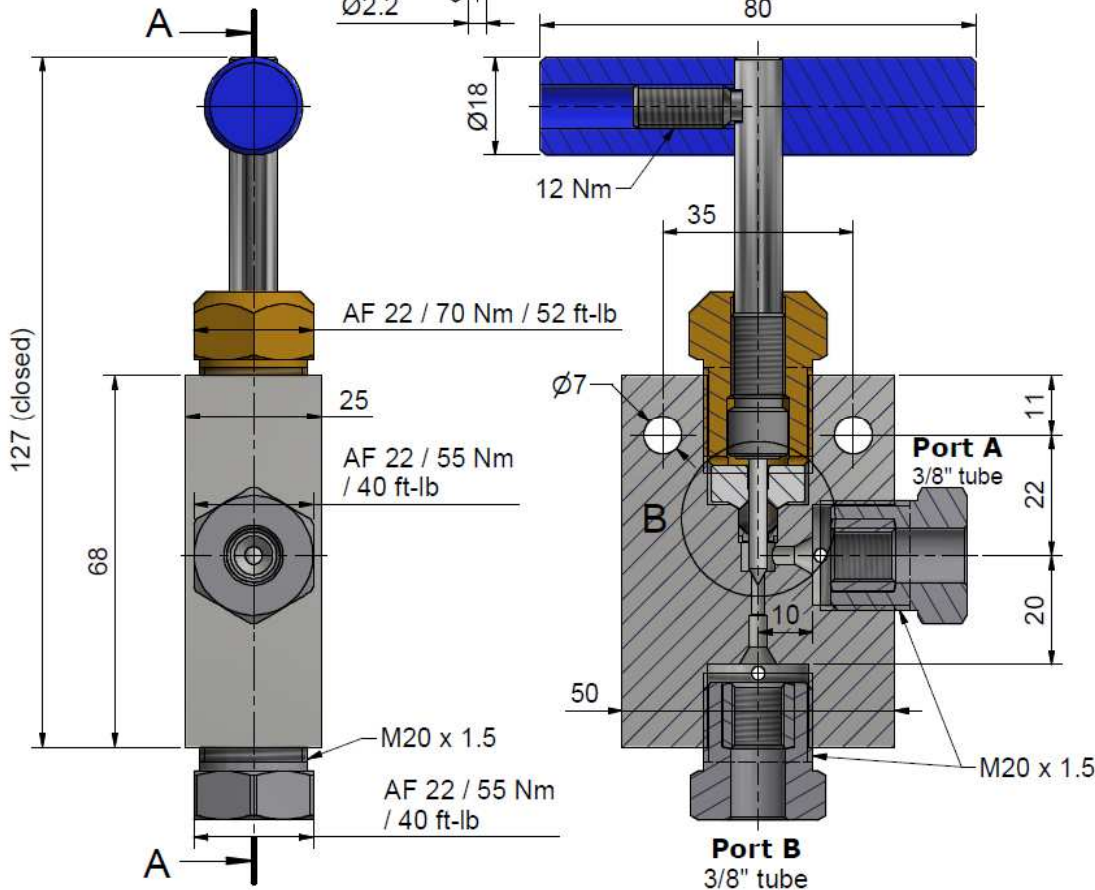

Item	Qty	Description	Part-Number	Comments	Weight
1	1	Spindle complete 2.0	910062		169.9 g
1.1	1	Needle with spindle 2.0	912059	Wear part	39.9 g
1.2	1	Spindle Nut 2.0	912058		75.1 g
1.3	1	Clamp Handle 2.0	912057		48.2 g
1.4	1	Screw	000044		6.7 g
2	1	Pressure plate 2.0	912053	Wear part	11.8 g
3	1	HP-Seal 2.0	912052	Wear part	1 g
4	1	Valve Body angle 3/8" 2.0	912066	Wear part	530.7 g
5	1	Conical disc 2.0	912062	Wear part	0.4 g
6	2	Gland Nut 3/8"	703800		48.1 g
7	2	Collar 3/8"	713800		6.8 g

General tolerances ISO 2768-1 m Designs and drawings created and produced by the contractor are the contractor's intellectual property and may only be used for the purposes of the order.

Amendment:	Replace for	912011, 910400
	Replaced by	-
	Drawn	28.07.2016 AM
	Checked	01.05.2017 RB
	Release	29.05.2017 BT
	Index-release	

Hand Valve 2-Way Angle 3/8" 2.0

Scale 1 : 1

Max 4150 bar / 60,000 psi
 Hand valve 2.0

ALLFI AG - RIEDENMATT 1 - CH-6370 STANS
 PHONE +41(0)41-618 05 05 - TELEFAX +41(0)41-618 05 10
 E-MAIL: sales@allfi.com http://www.allfi.com

910410

Index	Sheet- No.	2
	No. of sheets	2