

Assembling - Maintenance

This drawing is appendix A of the installation and maintenance instruction "Pneumatic Valve 2.0". Complete installation and maintenance instruction refer to QR-Code or: <https://www.allfi.com/en/services/downloads/product-manuals/>

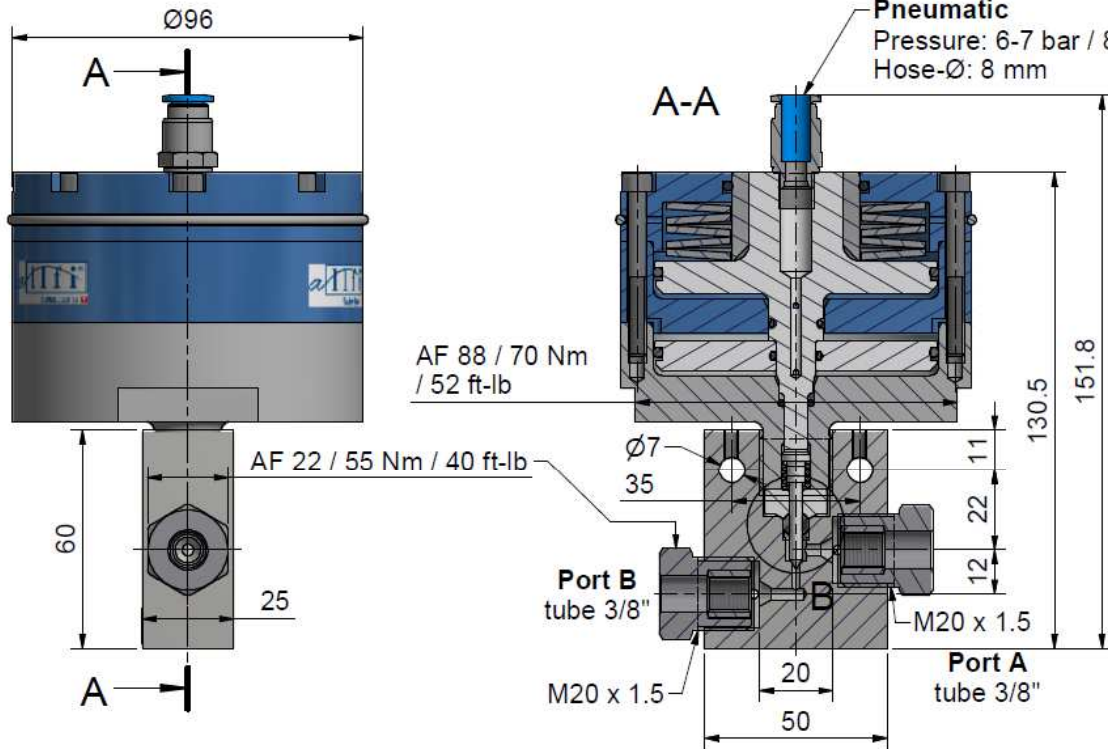

- Pressure relief holes must not be covered or closed.



Detail B (2 : 1)

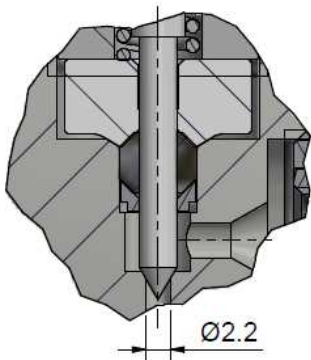

*) -> Assembly-Grease DX
Allfi-Art.: 051055



Sealing kit 2.0
912050
Including Pos.
2,3,4,5,6

Item	Qty	Description	Part-Number	Comments	Weight
1	1	Pneumatic cylinder 2.0 NC	912190		2293.9 g
2	1	Needle complete 2.0	912076	Wear part	2.2 g
3	1	Spring	021033		0.1 g
4	1	Pressure plate 2.0	912053	Wear part	11.8 g
5	1	HP-Seal 2.0	912052	Wear part	1 g
6	1	Conical disc 2.0	912062	Wear part	0.4 g
7	1	Valve Body straight 3/8" 2.0	912065	Wear part	451.6 g
8	2	Collar 3/8"	713800		6.8 g
9	2	Gland Nut 3/8"	703800		48.1 g

General tolerances ISO 2768-1 m Designs and drawings created and produced by the contractor are the contractor's intellectual property and may only be used for the purposes of the order. Weight 2.87 kg

Amendment:	Replace for:	-
	Replaced by:	-
	Drawn:	24.03.2017 AM
Pneum. Valve 2-Way Straight 3/8" NC 2.0	Scale	2 : 3
	Checked:	05.12.2017 RB
	Release:	05.12.2017 RB
	Index-release:	

allfi Components
ALLFI AG - RIEDENMATT 1 - CH-6370 STANS
PHONE +41(0)41-618 05 05
E-MAIL: sales@allfi.com <http://www.allfi.com>

Max 4150 bar / 60,000 psi
Normally closed

910170	Index:	-	Sheet- No.	2
			No. of sheets	2