

Assembling - Maintenance

This drawing is appendix A of the installation and maintenance instruction "Hand valve 2.0". Complete installation and maintenance instruction refer to QR-Code or: <https://www.allfi.com/en/services/downloads/product-manuals/>

- Pressure relief holes must not be covered or closed.



Detail B (2 : 1)

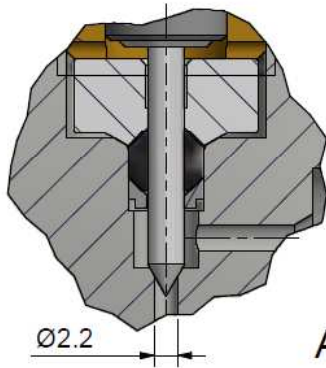

A-A

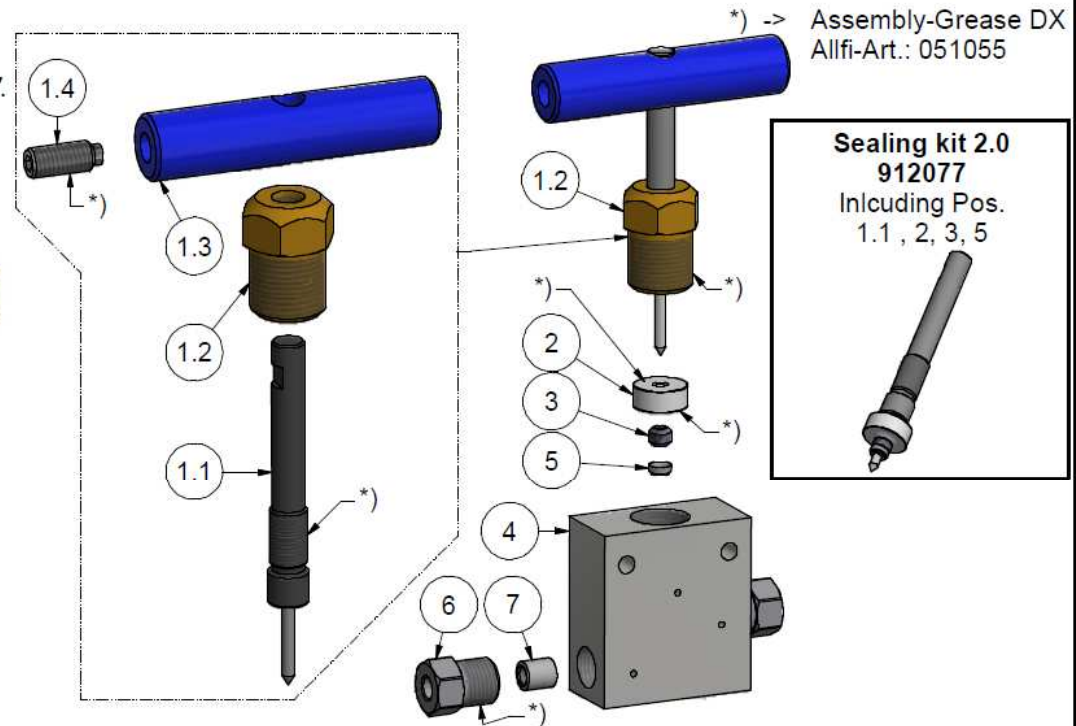
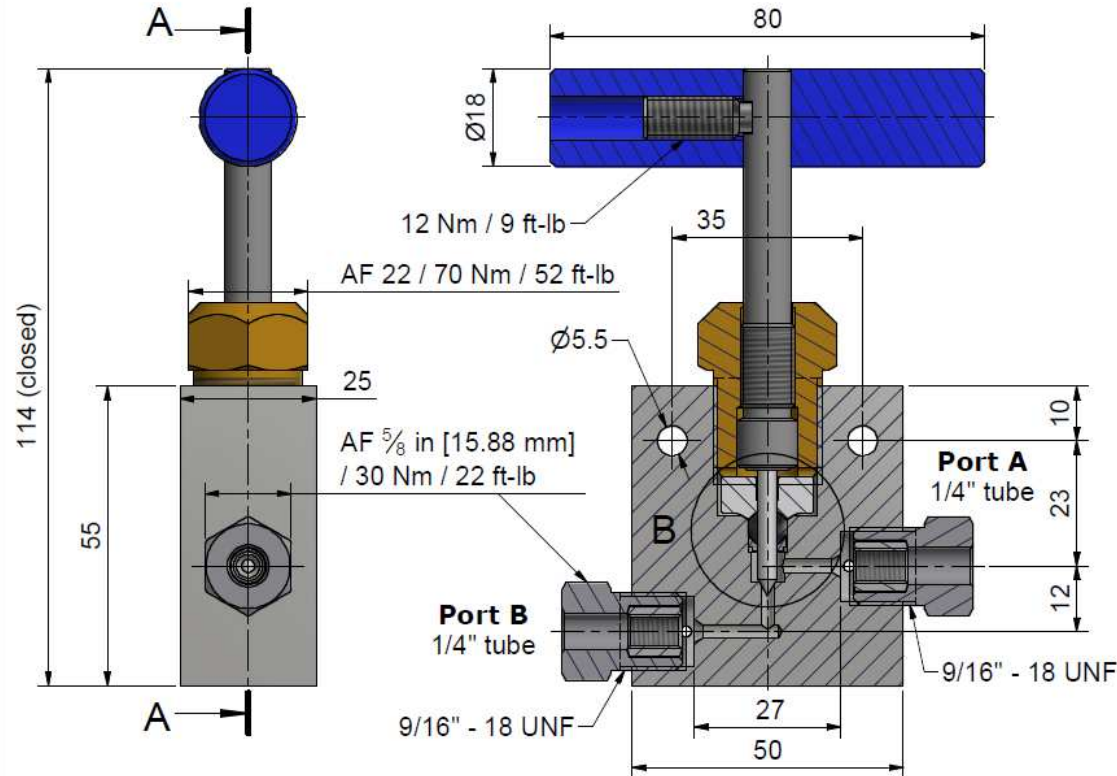
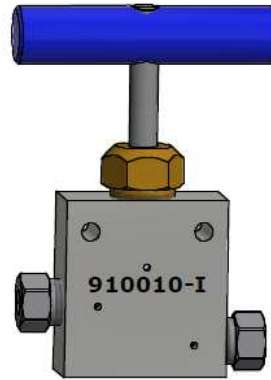

Item	Qty	Description	Part-Number	Comments	Weight
1	1	Spindle complete 2.0	910062		169.9 g
1.1	1	Needle with spindle 2.0	912059	Wear part	39.9 g
1.2	1	Spindle Nut 2.0	912058		75.1 g
1.3	1	Clamp Handle 2.0	912057		48.2 g
1.4	1	Screw	000044		6.7 g
2	1	Pressure plate 2.0	912053	Wear part	11.8 g
3	1	HP-Seal 2.0	912052	Wear part	1 g
4	1	Valve Body straight 1/4" 2.0 Imp	912051-I	Wear part	449.5 g
5	1	Conical disc 2.0	912062	Wear part	0.4 g
6	2	Gland Nut 1/4" Imp	701407		22.8 g
7	2	Collar 1/4"	711403		3.1 g

General tolerances ISO 2768-1 m | Designs and drawings created and produced by the contractor are the contractor's intellectual property and may only be used for the purposes of the order. | Weight

Amendment:	Replace for 912000-I
	Replaced by -
Drawn	05.09.2016 AM
Checked	02.05.2017 RB
Release	29.05.2017 BT
Index-release	

Hand Valve 2-Way Straight 1/4" 2.0 Imp

Scale: 1 : 1

Max 4150 bar / 60,000 psi
Hand valve 2.0

910010-I

ALLFI AG - RIEDENMATT 1 - CH-6370 STANS
PHONE +41(0)41-618 05 05 - TELEFAX +41(0)41-618 05 10
E-MAIL: sales@allfi.com http://www.allfi.com

Index	Sheet-	2
	No. of	
	sheets	2