

Assembling - Maintenance

This drawing is appendix A of the installation and maintenance instruction "Cutting head type IV 2.0". Complete installation and maintenance instruction refer to QR-Code or: <https://www.allfi.com/en/services/downloads/product-manuals/>

- Pneumatic-cylinder must be pressurised with air during assembling and disassembling of valve case and collimation tube.
- Stroke has to be 0.6 - 0.8 mm / 0.0235 - 0.0315", air pressure 7bar - 100 psi, adjustment range +/- 1 revolution.
- Function test with several open and closed cycles.
- After finishing maintenance flush the complete cutting head without nozzle at < 500 bar / 7200 psi.
- Pressure relief holes must not be covered or closed.
- Use only orifice Typ 94.

Pneumatic

Pressure: 6-7 bar / 88-100 psi
Hose-Ø: 6 mm
Pressure at stroke-adjustment: 7 bar / 100 psi

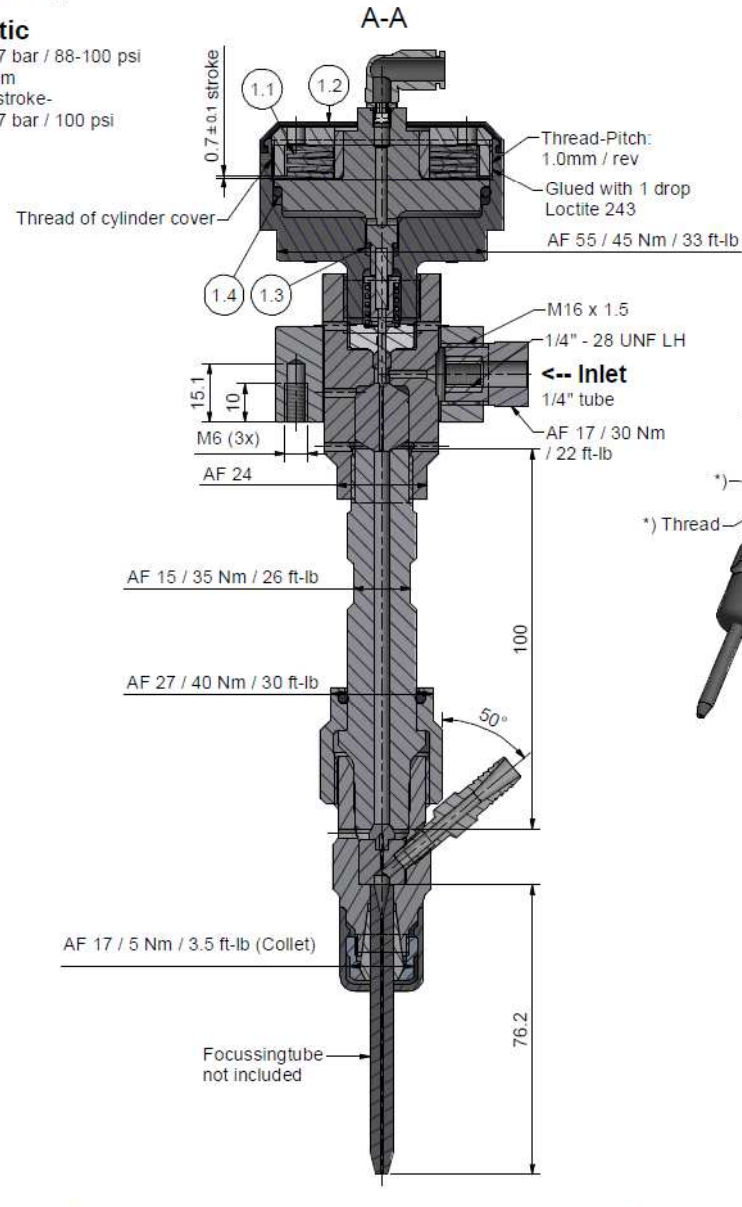
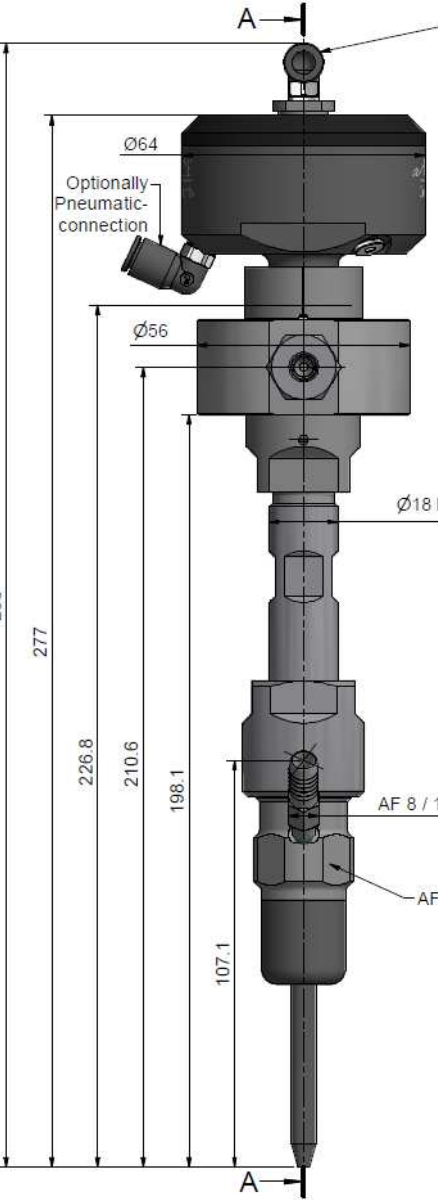
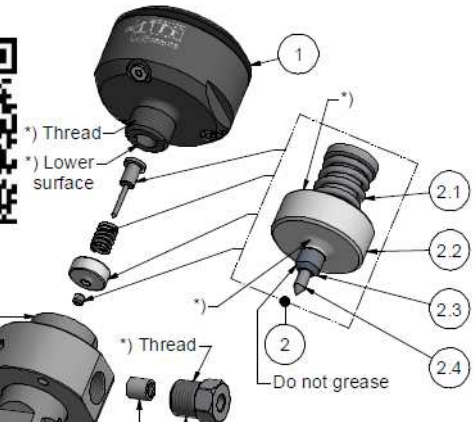
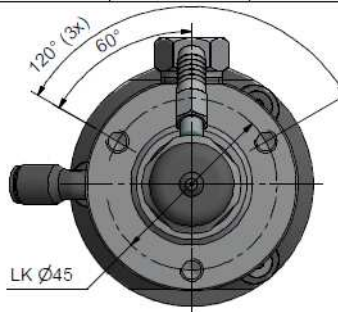

Item	Qty	Description	Part-Number	Comments	Weight
1	1	Pneumatic cylinder type IV 2.0	908290		340.2 g
1.1	5	Disc Spring	021001		14.3 g
1.2	1	Rubber cover	908092		3.9 g
1.3	1	O-Ring D=5.5 x 1.5	010006		0 g
1.4	1	O-Ring D=52.07 x 2.62	010090		0.9 g
2	1	Seal Kit 2.0	901432	Wear part	15.6 g
2.1	1	Compression Spring	021006		1.4 g
2.2	1	Pressure plate 2.0	900627		11 g
2.3	1	HP-seal 2.0	900622		0.1 g
2.4	1	Valve needle	901416		3.1 g
3	1	Valve case 2.0	908010	Wear part	235.2 g
4	1	Coupling Ring	900074		305.8 g
5	1	Valve Seat	900014	Wear part	17.2 g
6	1	O-Ring D=14 x 1.5	010013		0.1 g
7	1	Gland Nut 1/4"	701403		29.1 g
8	1	Collar 1/4"	711403		3.1 g
9	1	Collimation tube L=100 CL-IV	970079	Wear part	169.5 g
10	1	Orifice Type 94	0094xx	Not included	1.1 g
11	1	Abrasive Cutting Head Centerline Type IV	950880		269.4 g

General tolerances ISO 2768-1 mK

Amendment: _____

Replace for: _____

Replaced by: _____

Drawn: 19.06.2018 AM

Checked: 25.06.2018 RB

Release: 25.06.2018 RB

Index-release: _____

Scale: 1 : 1

Max. 4150 bar / 60,000 psi

908304

ALLFI AG - RIEDENMATT 1 - CH-8370 STANS
PHONE: +41(0)41-818 05 05
E-MAIL: sales@allfi.com <http://www.allfi.com>

Index: - Sheet-No.: 2 of 2 sheets