

Assembling - Maintenance

This drawing is appendix A of the installation and maintenance instruction "Cutting head type XIV 2.0". Complete installation and maintenance instruction refer to QR-Code or: <https://www.allfi.com/en/services/downloads/product-manuals/>

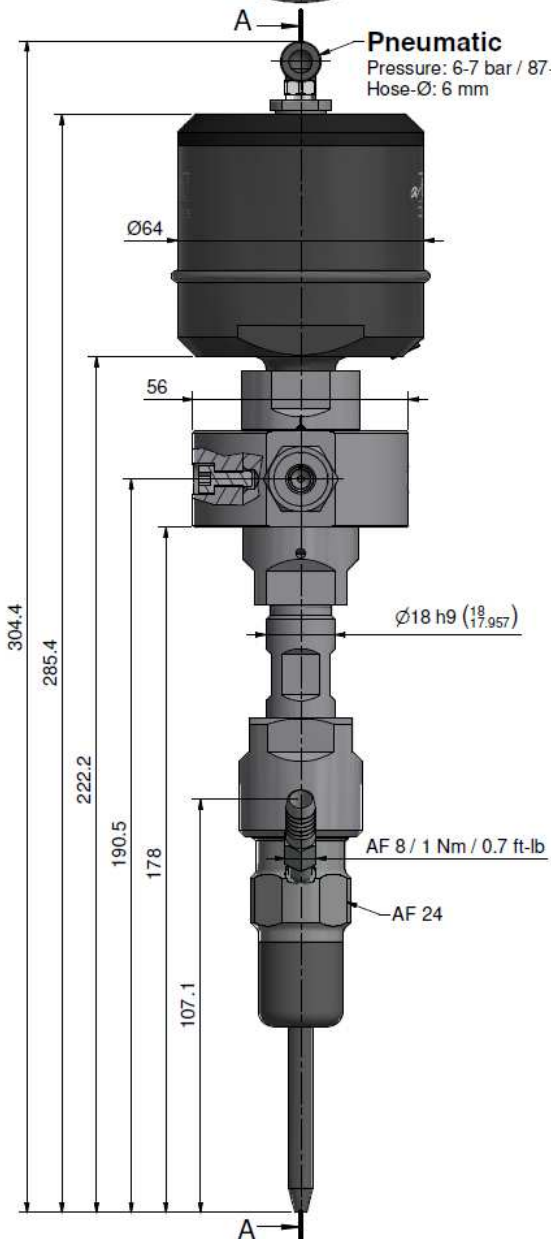

- Pneumatic-cylinder must be pressurised with air during assembling and disassembling of valve case and collimation tube.
- Stroke has to be 0.6 - 0.8 mm / 0.0235 - 0.0315", air pressure 7bar - 100 psi, adjustment range +/- 1 revolution.
- Function test with several open and closed cycles.
- After finishing maintenance flush the complete cutting head without nozzle at < 500 bar / 7200 psi.
- Pressure relief holes must not be covered or closed.
- Use only orifice Typ 94.

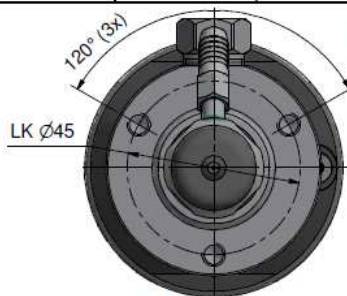

Pneumatic
Pressure: 6-7 bar / 87-101 psi
Hose-Ø: 6 mm

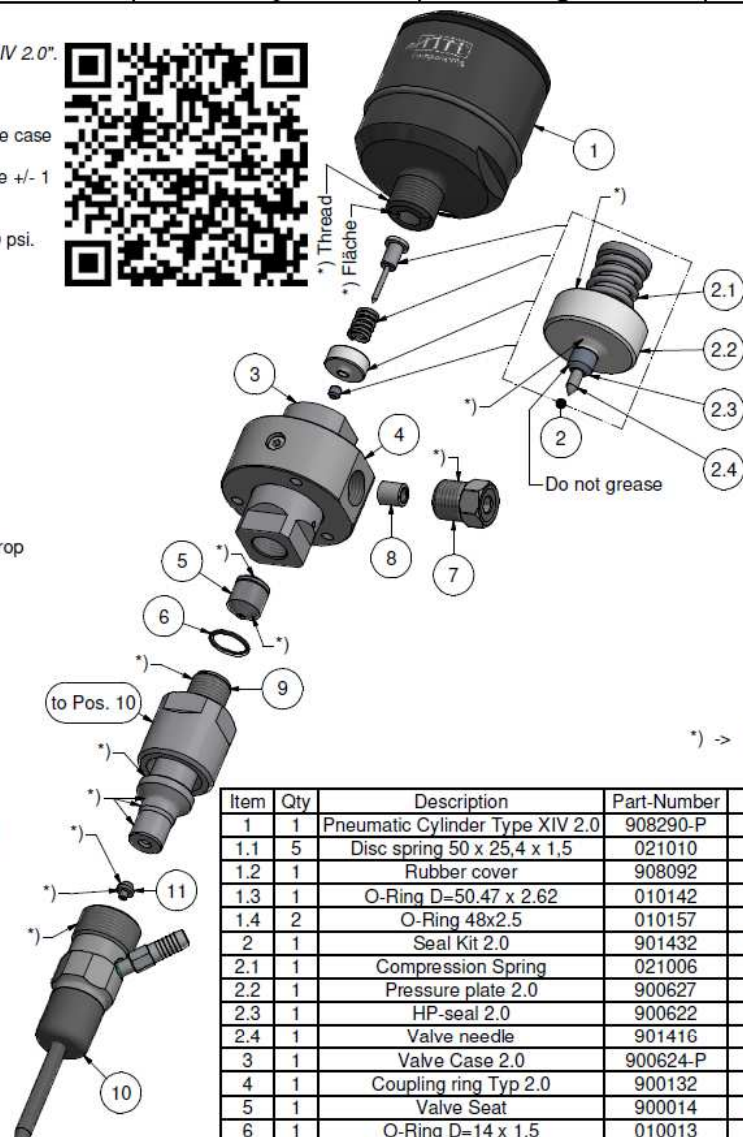
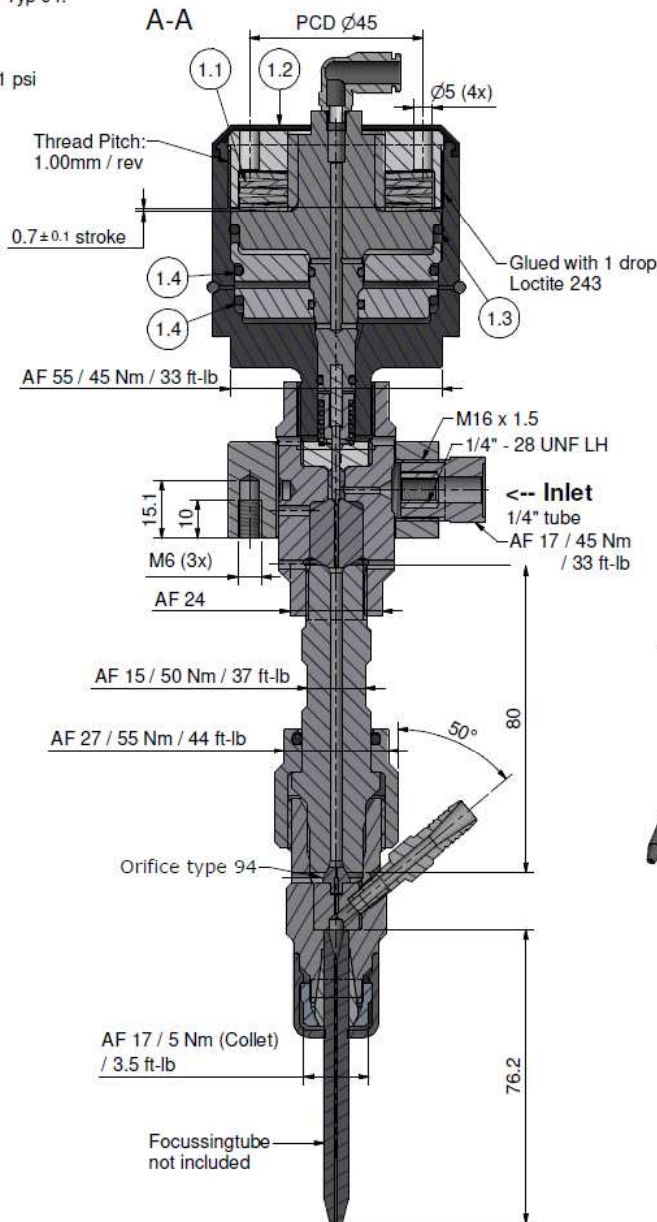

*) -> Assembly-Grease DX
ALLFI-Art.: 051055

Item	Qty	Description	Part-Number	Comments	Weight
1	1	Pneumatic Cylinder Type XIV 2.0	908290-P		489.1 g
1.1	5	Disc spring 50 x 25,4 x 1,5	021010		2.2 g
1.2	1	Rubber cover	908092		3.9 g
1.3	1	O-Ring D=50.47 x 2.62	010142		0.8 g
1.4	2	O-Ring 48x2.5	010157		0.7 g
2	1	Seal Kit 2.0	901432	Wear part	15.6 g
2.1	1	Compression Spring	021006		1.4 g
2.2	1	Pressure plate 2.0	900627		11 g
2.3	1	HP-seal 2.0	900622		0.1 g
2.4	1	Valve needle	901416		3.1 g
3	1	Valve Case 2.0	900624-P	Wear part	236.1 g
4	1	Coupling ring Typ 2.0	900132		306.8 g
5	1	Valve Seat	900014	Wear part	17.2 g
6	1	O-Ring D=14 x 1.5	010013		0.1 g
7	1	Gland Nut 1/4" 90.000psi	701403-P		27.9 g
8	1	Collar 1/4"	711403		3.1 g
9	1	Collimation tube L=80 CL-IV	970072-P	Wear part	135.2 g
10	1	Abrasive Cutting Head Centerline Type IV	950880		269.4 g
11	1	Orifice Type 94	0094xx	Not included	1.1 g

General tolerances ISO 2768-1 mK

Amendment: A) 0159, 900132 was 900074, 16.11.2023 AM

Replace for: -
Replaced by: -
Drawn: 19.05.2021 AM
Checked: 28.10.2022 BT
Release: 28.10.2022 GB
Index-release: 04.01.2024 PH

Cutting head type XIV 2.0 AWJ

Scale: 1 : 1

Max. 6200 bar / 90,000 psi

908300-P

ALLFI AG - RIEDENMATT 1 - CH-6370 STANS
PHONE +41(0)41-618 05 05 - TELEFAX +41(0)41-618 05 10
E-MAIL: sales@allfi.com http://www.allfi.com

Index Sheet No. 3
No. of sheets 2