

Assembling - Maintenance

This drawing is appendix A of the installation and maintenance instruction "Cutting head type XIV 2.0". Complete installation and maintenance instruction refer to QR-Code or:
<https://www.allfi.com/en/services/downloads/product-manuals/>

- Pneumatic-cylinder must be pressurised with air during assembling and disassembling of valve case and collimation tube.
- Stroke has to be 0.6 - 0.8 mm / 0.0235 - 0.0315"
- Function test with several open and closed cycles.
- After finishing maintenance flush the complete cutting head without nozzle at < 500 bar / 7200 psi.
- Pressure relief holes must not be covered or closed.

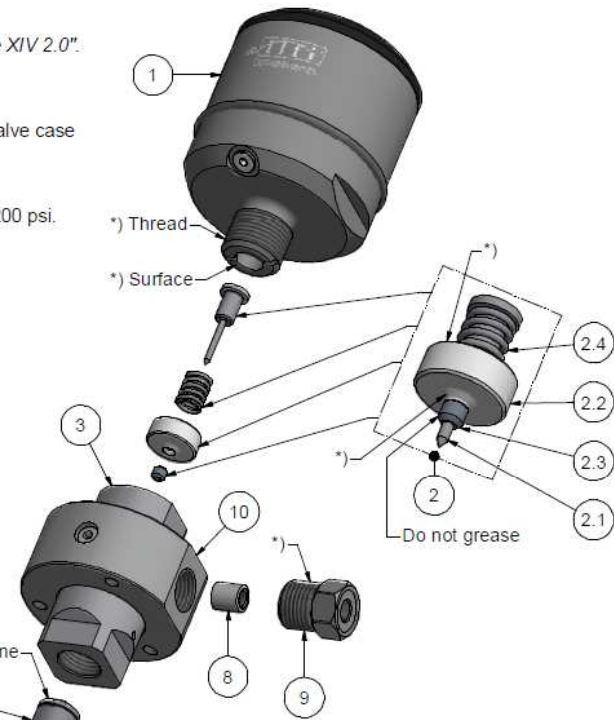
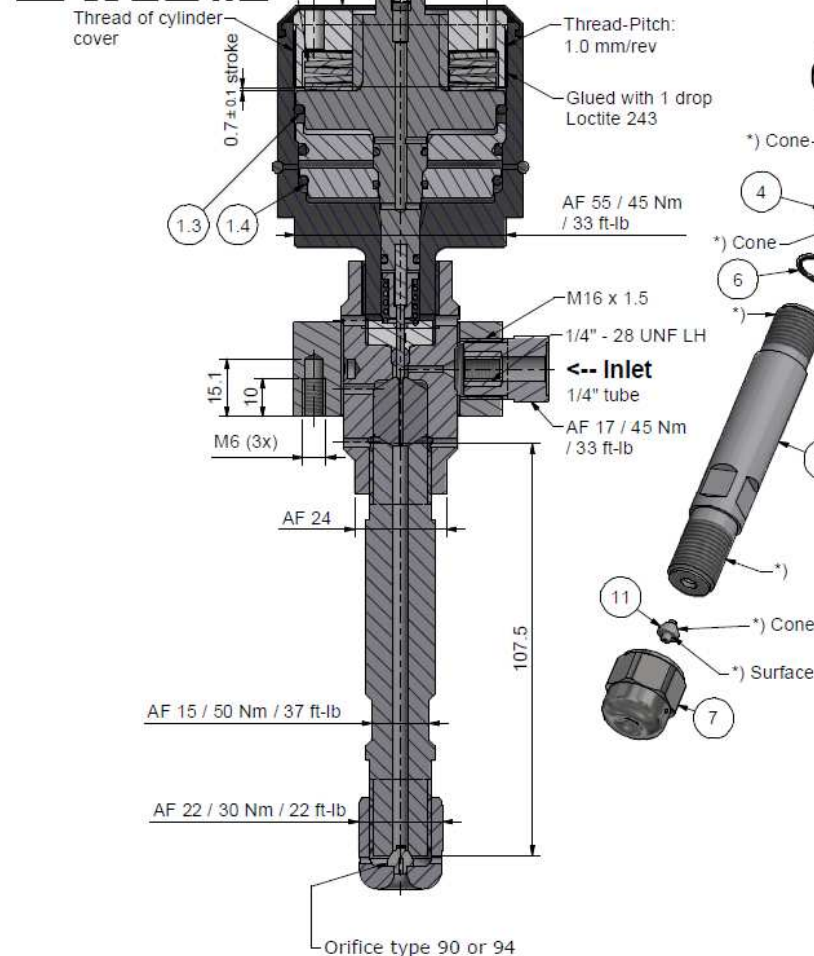

*) -> Assembly-Grease DX
ALLFI-Art.: 051055

Item	Qty	Description	Part-Number	Comments	Weight
1	1	Pneumatic Cylinder Type XIV 2.0	908290-P		490.2 g
1.1	5	Disc spring 50 x 25.4 x 1.5	021010		2.2 g
1.2	1	Rubber cover	908092		3.9 g
1.3	1	O-Ring D=50.47 x 2.62	010142		0.8 g
1.4	2	O-Ring 48x2.5	010157		0.7 g
2	1	Seal Kit 2.0	901432	Wear part	15.6 g
2.1	1	Valve needle	901416		3.1 g
2.2	1	Pressure plate 2.0	900627		11 g
2.3	1	HP-seal 2.0	900622		0.1 g
2.4	1	Compression Spring	021006		1.4 g
3	1	Valve Case 2.0	900624-P	Wear part	236.1 g
4	1	Valve Seat	900014	Wear part	17.2 g
5	1	Collimation tube L=107.5	900052-P	Wear part	178.3 g
6	1	O-Ring D=14 x 1.5	010013		0.1 g
7	1	Orifice Cap	900060-P		44 g
8	1	Collar 1/4"	711403		3.1 g
9	1	Gland Nut 1/4" 90.000psi	701403-P		27.9 g
10	1	Coupling ring Typ 2.0	900132		306.8 g
11	1	Orifice ring 90 / 94	-	Not included	1.1 g

General tolerances ISO 2768-1 mK Designs and drawings created and produced by the contractor are the contractor's intellectual property and may only be used for the purposes of the order.

Amendment:		Replace for
A) 05.09.2021 was 900074, 16.11.2023 AM		-
Drawn		22.12.2021 AM
Checked		25.01.2022 RB
Release		09.09.2022 GB
Index-released		04.01.2024 PH

Cutting head type XIV 2.0 PWJ

Scale
1 : 1

Max. 6200 bar / 90,000 psi



ALLFI AG - RIEDENMATT 1 - CH-8370 STANS
 PHONE +41(0)41-818 05 05
 E-MAIL: sales@allfi.com

<http://www.allfi.com>

908200-P

Index Sheet No. 2
No. of sheets 2

Pneumatic
 Pressure: 6-7 bar / 87-101 psi
 Hose-Ø: 6 mm

