

1 : 2 120° (3x)

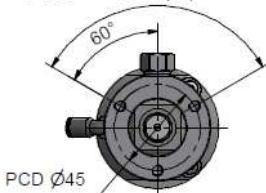

Assembling - Maintenance

This drawing is appendix A of the installation and maintenance instruction "Cutting head type V 2.0". Complete installation and maintenance instruction refer to QR-Code or: <https://www.allfi.com/en/services/downloads/product-manuals/>

- Pneumatic-cylinder must be pressurised with air during assembling and disassembling of valve case and collimation tube.
- Stroke has to be 0.6 - 0.8 mm / 0.0235 - 0.0315", air pressure 7bar - 100 psi, adjustment range +/- 1 revolution.
- Function test with several open and closed cycles.
- After finishing maintenance flush the complete cutting head without nozzle at < 500 bar / 7200 psi.
- Pressure relief holes must not be covered or closed.

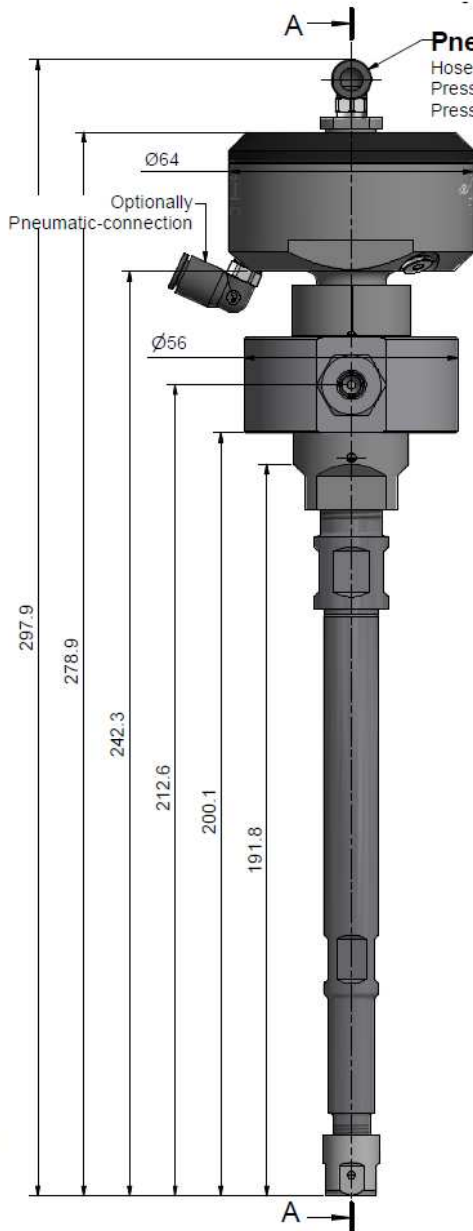
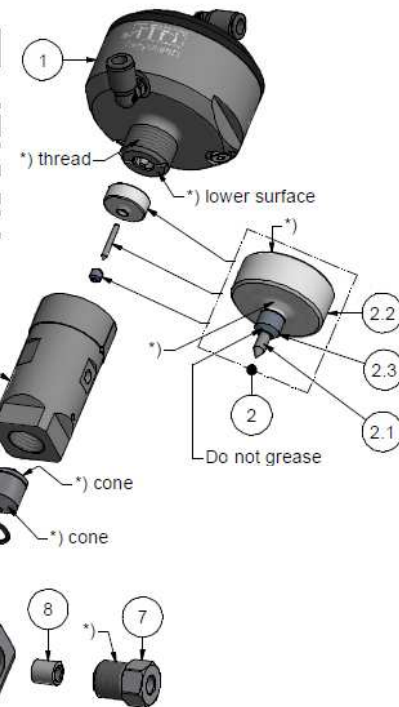

Pneumatic

Hose-Ø: 6 mm
Pressure in operation: 6-7 bar / 88-100 psi
Pressure at stroke adjustment: 7 bar / 100 psi

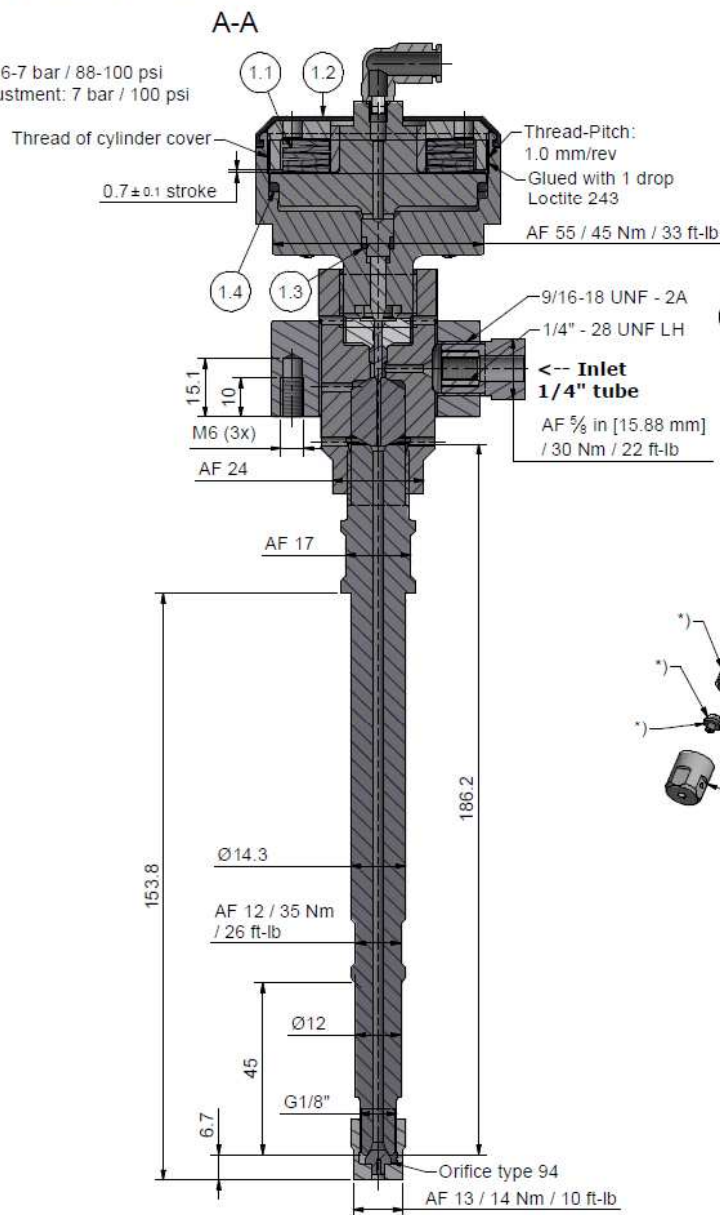

*) -> Montage-Paste DX ALLFI-Art.: 051055

Item	Qty	Description	Part-Number	Comments	Weight
1	1	Pneumatic cylinder type V 2.0	908090		343.3 g
1.1	5	Disc Spring	021001		14.3 g
1.2	1	Rubber cover	908092		3.9 g
1.3	1	O-Ring D=5.5 x 1.5	010006		0 g
1.4	1	O-Ring D=52.07 x 2.62	010090		0.9 g
2	1	Seal Kit 2.0	901433	Wear part	11.5 g
2.1	1	Needle	900616		0.4 g
2.2	1	Pressure plate 2.0	900627		11 g
2.3	1	HP-seal 2.0	900622		0.1 g
3	1	Valve case 2.0	908010	Wear part	235.2 g
4	1	Coupling Ring 1/4" Imp	900074-I		309.1 g
5	1	Valve Seat	900014	Wear part	17.2 g
6	1	O-Ring D=14 x 1.5	010013		0.1 g
7	1	Gland Nut 1/4" Imp	701407		22.8 g
8	1	Collar 1/4"	711403		3.1 g
9	1	Collimation Tube L=186.2	970090	Wear part	221.4 g
10	1	Nozzle cap	900460		13.4 g
11	1	Orifice Type 94	0094xx	Not included	1.1 g

General tolerances ISO 2768-1 mK

Amendment:

Replace for	-
Replaced by	-
Drawn	14.04.2022 AM
Checked	25.04.2022 GB
Release	25.04.2022 GB
Index-release	

Cutting head type V 2.0 PWJ SP13 Imp

Scale 1 : 1

Max. 4150 bar / 60,000 psi KMT

908015-I

ALLFI AG - RIEDENMATT 1 - CH-6370 STANS
PHONE +41(0)41-818 05 05
E-MAIL: sales@allfi.com http://www.allfi.com

Index Sheet No. 2 No. of sheets 2