

### Assembling - Maintenance

This drawing is appendix A of the installation and maintenance instruction "Cutting head type V 2.0". The complete installation and maintenance instruction is hosted at [www.alfi.com](http://www.alfi.com)

- Pneumatic-cylinder must be pressurised with air during assembling and disassembling of valve case and collimation tube
- Stroke adjustment: Stroke 0.6 - 0.8 mm / 0.0235 - 0.0315", air pressure 7 bar - 100 psi, adjustment range +/- 1 revolution (Attention: Thread of cylinder cover must not be visible)
- Function test with several open and closed cycles
- After finishing maintenance flush the complete cutting head without nozzle at < 500 bar / 7,200 psi
- Pressure relief holes must not be covered or closed

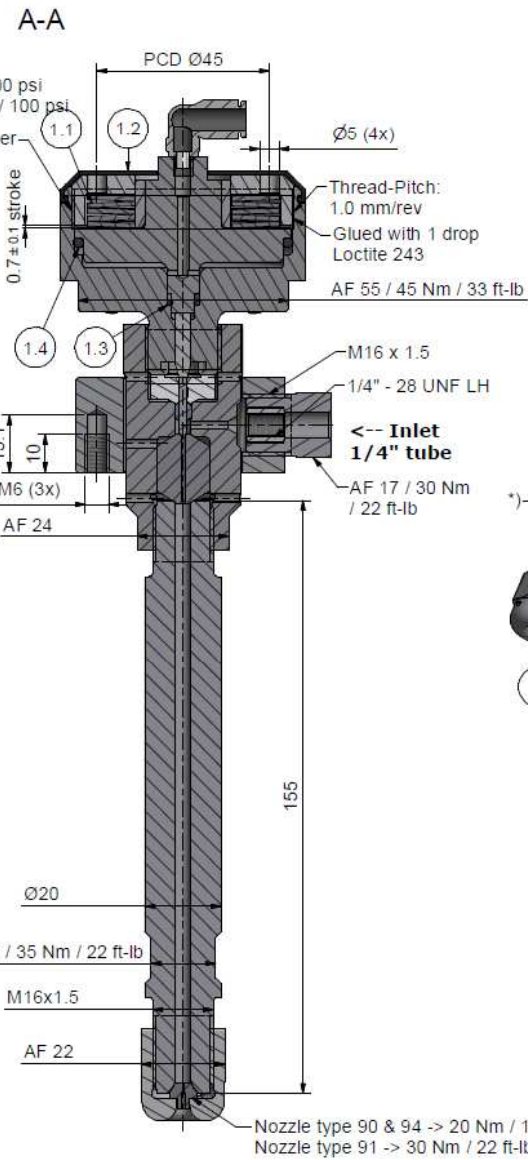
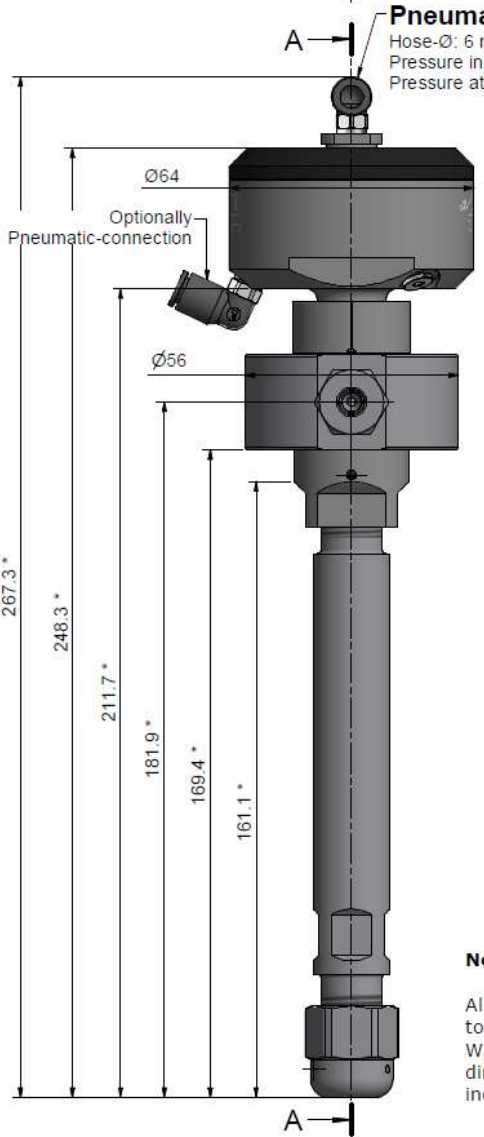

**Note \***  
 All dimensions refer to nozzle type 90 & 94. When using type 91 all dimensions will increase by 2.5mm

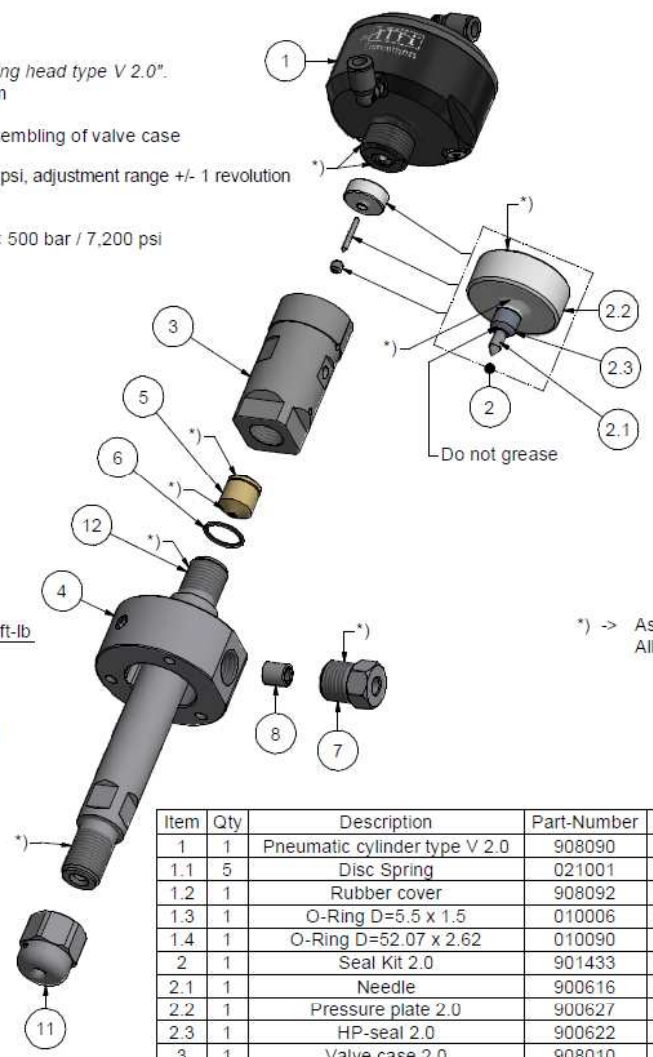

\*) -> Assembly-Grease DX  
 Alfi-Art.: 051055

Item	Qty	Description	Part-Number	Comments	Weight
1	1	Pneumatic cylinder type V 2.0	908090		343.3 g
1.1	5	Disc Spring	021001		14.3 g
1.2	1	Rubber cover	908092		3.9 g
1.3	1	O-Ring D=5.5 x 1.5	010006		0 g
1.4	1	O-Ring D=52.07 x 2.62	010090		0.9 g
2	1	Seal Kit 2.0	901433	Wear part	11.5 g
2.1	1	Needle	900616		0.4 g
2.2	1	Pressure plate 2.0	900627		11 g
2.3	1	HP-seal 2.0	900622		0.1 g
3	1	Valve case 2.0	908010	Wear part	235.2 g
4	1	Coupling Ring	900074		305.8 g
5	1	Valve Seat	900014	Wear part	17.2 g
6	1	O-Ring D=14 x 1.5	010013		0.1 g
7	1	Gland Nut 1/4"	701403		29.1 g
8	1	Collar 1/4"	711403		3.1 g
11	1	Orifice Cap M16 x 1.5	900060		47.1 g
12	1	Collimation tube - L155	900099		318.1 g
13	1	Orifice Type 94	0094xx		1.1 g

General tolerances ISO 2768-1 m

Designs and drawings created and produced by the contractor are the contractor's intellectual property and may only be used for the purposes of the order.

Weight: 1.31 kg

Amendment: \_\_\_\_\_

Replace for: \_\_\_\_\_

Replaced by: \_\_\_\_\_

Drawn: 28.11.2018 AM

Checked: 28.11.2018 RB

Release: 28.11.2018 RB

Index-release: \_\_\_\_\_

## Cutting head type V 2.0 PWJ SP7

Scale: 1 : 1

Max. 4150 bar / 60,000 psi

908008

ALFI AG - RIEDENMATT 1 - CH-8370 STANS  
 PHONE +41(0)41-818 05 05 - TELEFAX +41(0)41-818 05 10  
 E-MAIL: [sales@alfi.com](mailto:sales@alfi.com) <http://www.alfi.com>

Index: -

Sheet: 2

No. of sheets: 2