

Assembling - Maintenance

This drawing is appendix A of the installation and maintenance instruction "Cutting head type V 2.0".
Complete installation and maintenance instruction refer to QR-Code or:
<https://www.allfi.com/en/services/downloads/product-manuals/>

- Pneumatic-cylinder must be pressurised with air during assembling and disassembling of valve case and collimation tube.
- Stroke has to be 0.6 - 0.8 mm / 0.0235 - 0.0315"
- Function test with several open and closed cycles.
- After finishing maintenance flush the complete cutting head without nozzle at < 500 bar / 7200 psi.
- Pressure relief holes must not be covered or closed.

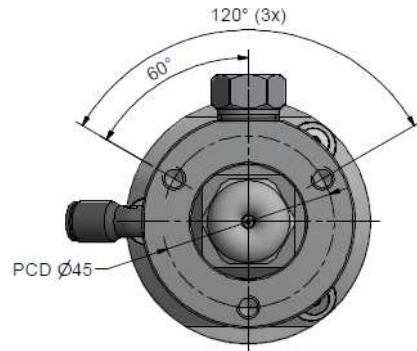

Pneumatic

Hose-Ø: 6 mm
Pressure in operation: 6-7 bar / 88-100 psi
Pressure at stroke adjustment: 7 bar / 100 psi

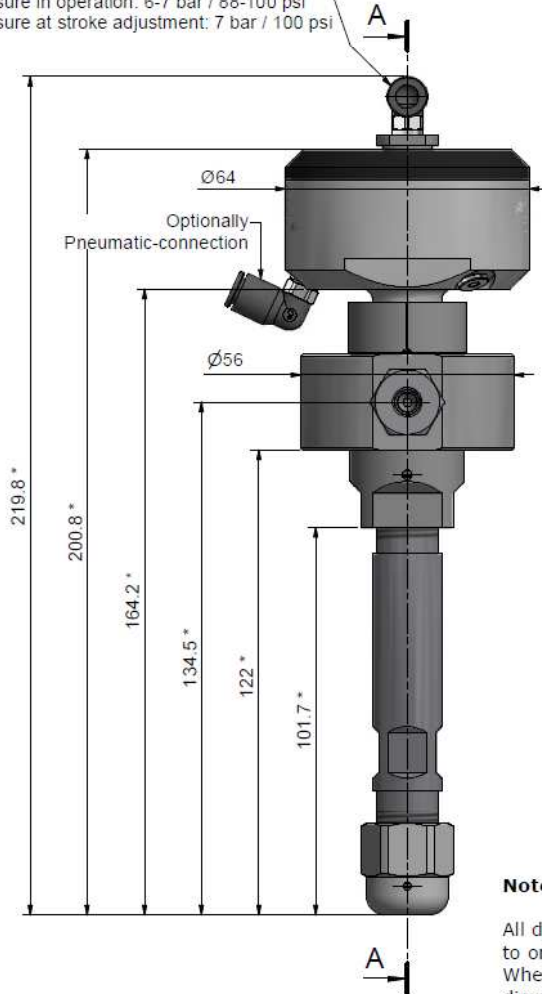

Note *

All dimensions refer to orifice type 90 & 94. When using type 91 all dimensions will increase by 2.5mm

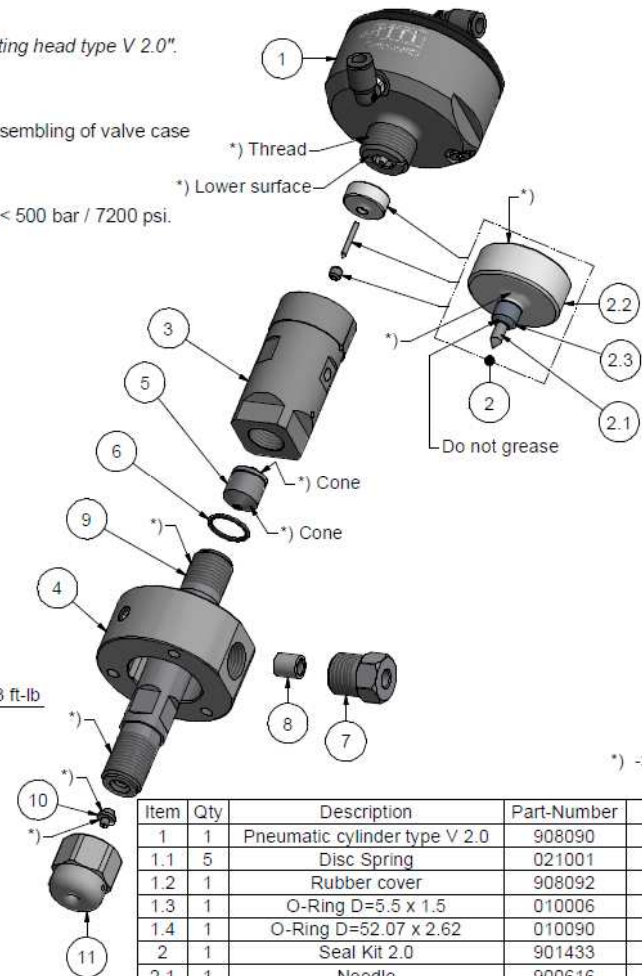
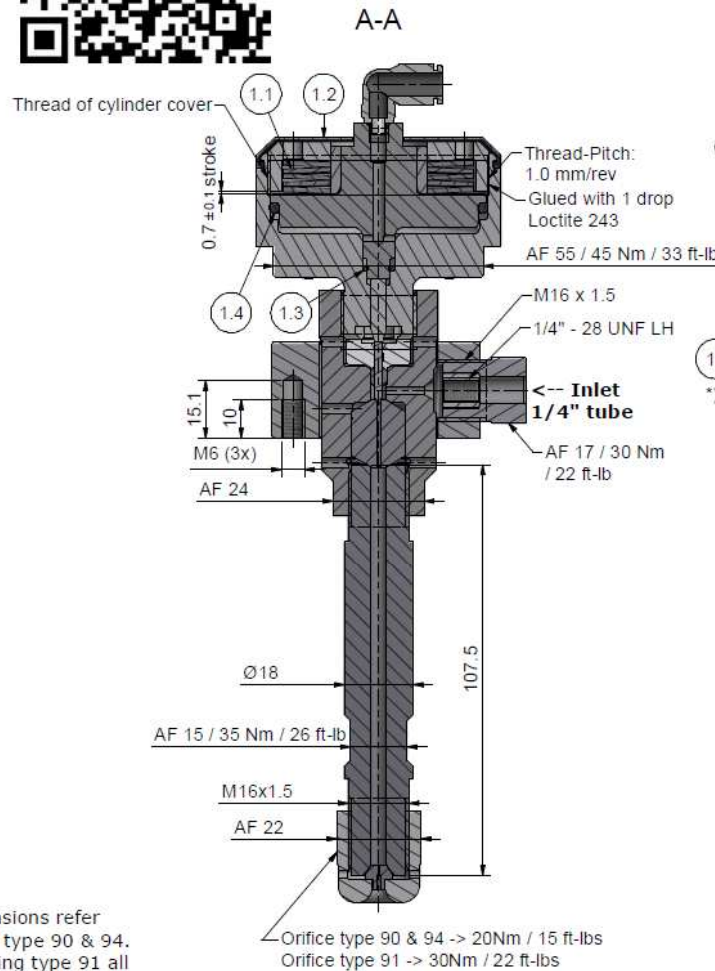

*) -> Assembly-Grease DX
ALLFI-Art.: 051055

Item	Qty	Description	Part-Number	Comments	Weight
1	1	Pneumatic cylinder type V 2.0	908090		343.3 g
1.1	5	Disc Spring	021001		14.3 g
1.2	1	Rubber cover	908092		3.9 g
1.3	1	O-Ring D=5.5 x 1.5	010006		0 g
1.4	1	O-Ring D=52.07 x 2.62	010090		0.9 g
2	1	Seal Kit 2.0	901433	Wear part	11.5 g
2.1	1	Needle	900616		0.4 g
2.2	1	Pressure plate 2.0	900627		11 g
2.3	1	HP-seal 2.0	900622		0.1 g
3	1	Valve case 2.0	908010	Wear part	235.2 g
4	1	Coupling Ring	900074		305.8 g
5	1	Valve Seat	900014	Wear part	17.2 g
6	1	O-Ring D=14 x 1.5	010013		0.1 g
7	1	Gland Nut 1/4"	701403		29.1 g
8	1	Collar 1/4"	711403		3.1 g
9	1	Collimation tube - L107.5	900052	Wear part	178 g
10	1	Orifice Type 94	0094xx	Not included	1.1 g
11	1	Orifice Cap M16 x 1.5	900060		47.1 g

General tolerances ISO 2768-1 mK Designs and drawings created and produced by the contractor are the contractor's intellectual property and may only be used for the purposes of the order.

Amendment:		Replace for	
Replaced by		-	
Drawn	10.11.2017	AM	
Checked	01.05.2018	RB	
Release	01.05.2018	RB	
Index-release			

Cutting head type V 2.0 PWJ

Scale
1 : 1

Max. 4150 bar / 60,000 psi



ALLFI AG - RIEDENMATT 1 - CH-8370 STANS
PHONE +41(0)41-818 05 05
E-MAIL: sales@allfi.com

<http://www.allfi.com>

908000

Index Sheet-
No. of sheets 2