

## Assembling - Maintenance

This drawing is appendix A of the installation and maintenance instruction "Cutting head type X 2.0".

Complete installation and maintenance instruction refer to QR-Code or:  
<https://www.allfi.com/en/services/downloads/product-manuals/>

- Pneumatic-cylinder must be pressurised with air during assembling and disassembling of valve case and collimation tube.
- Stroke has to be 0.6 - 0.8 mm / 0.0235 - 0.0315", air pressure 7bar - 100psi, adjustment range +/- 1 revolution.
- Function test with several open and closed cycles.
- After finishing maintenance flush the complete cutting head without nozzle at < 500 bar / 7200 psi.
- Pressure relief holes must not be covered or closed.

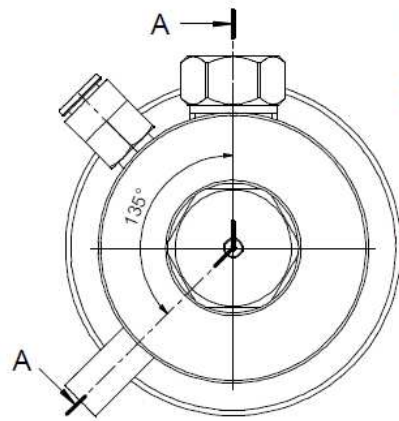

### Pneumatic

Hose-Ø: 6 mm  
 Pressure in operation:  
 6-7 bar / 87-101 psi

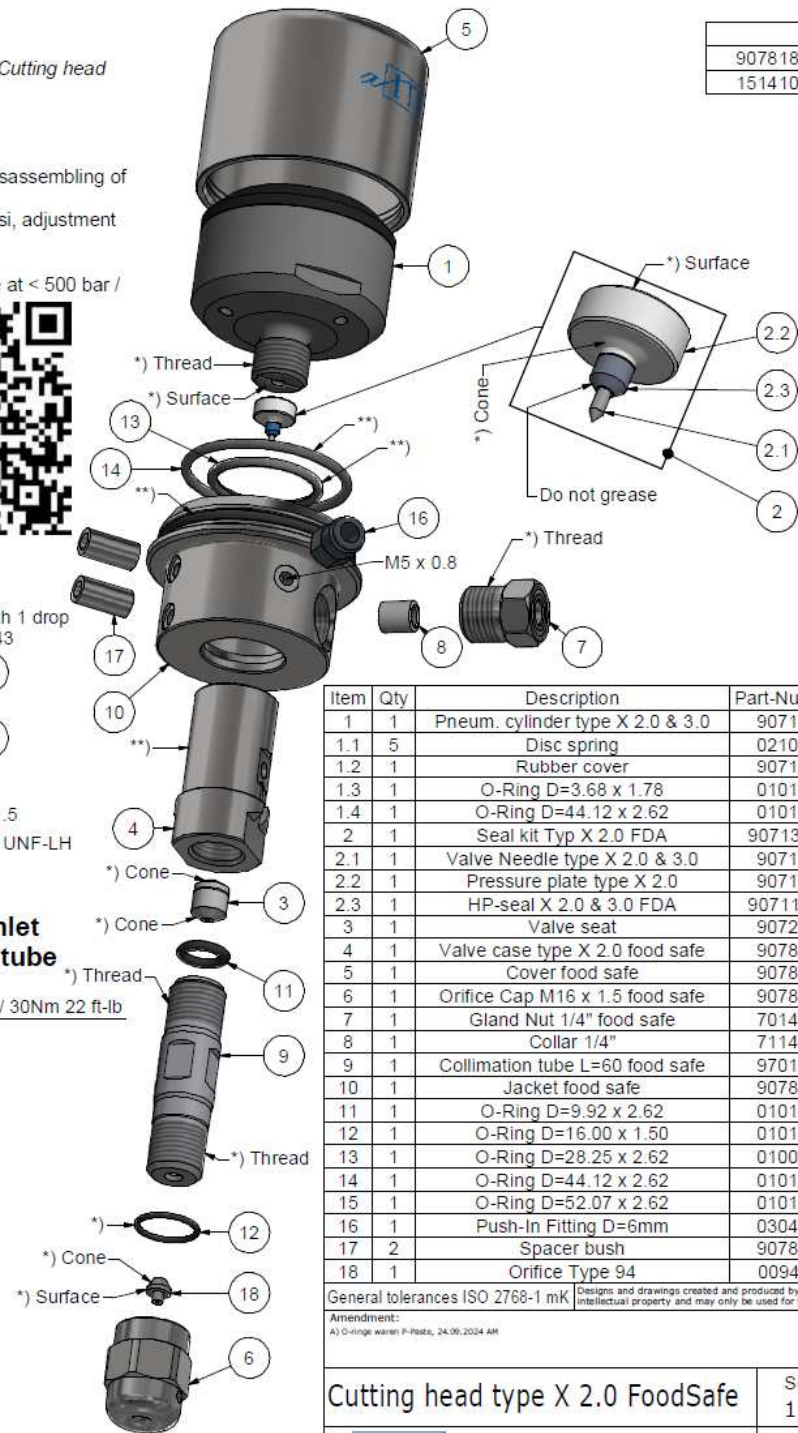
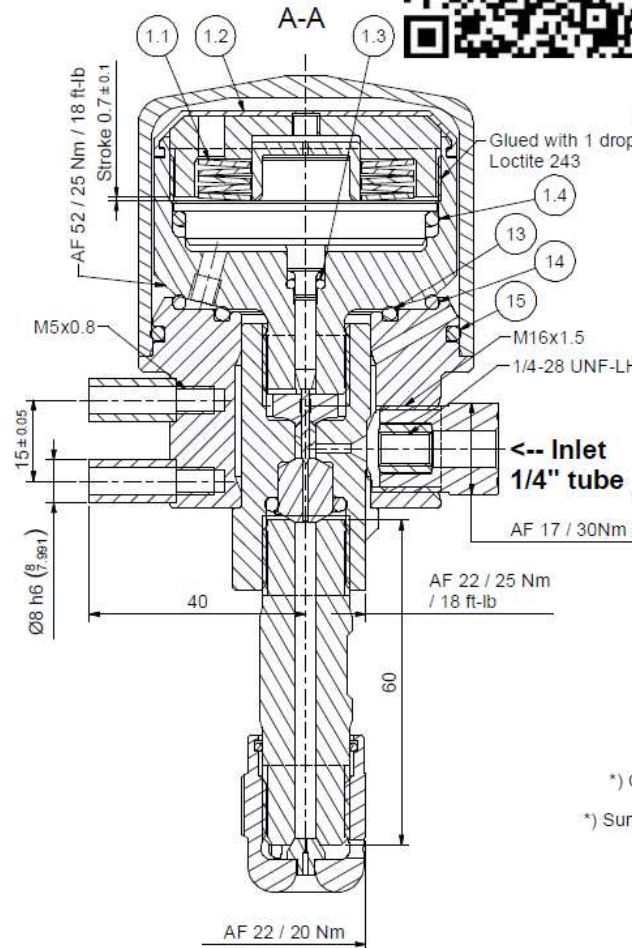
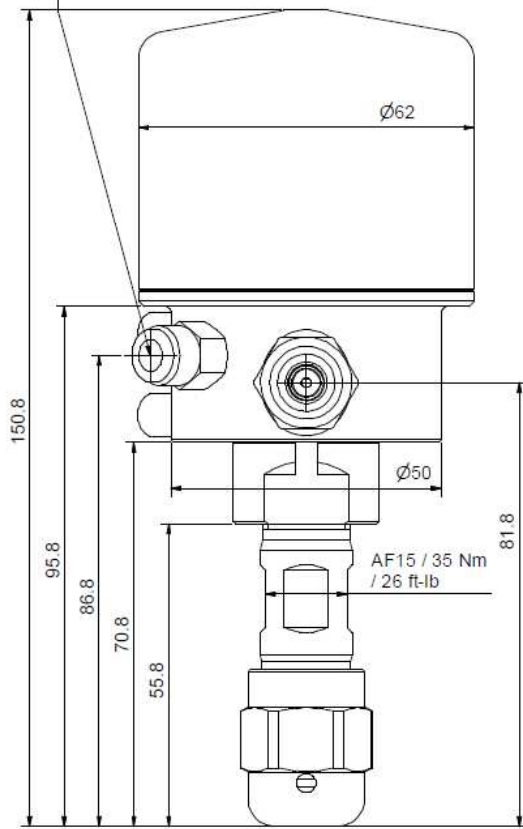

| Special tools |                |
|---------------|----------------|
| 907818        | Tool AF=52     |
| 151410        | Plug male 1/4" |

- \*) -> P-Paste  
ALLFI-Art. 051065
- \*\*) -> Silicon Grease  
ALLFI-Art.: 051021

| Item | Qty | Description                      | Part-Number | Comments     | Weight  |
|------|-----|----------------------------------|-------------|--------------|---------|
| 1    | 1   | Pneum. cylinder type X 2.0 & 3.0 | 907190      |              | 251.3 g |
| 1.1  | 5   | Disc spring                      | 021028      |              | 7.4 g   |
| 1.2  | 1   | Rubber cover                     | 907192      |              | 3.3 g   |
| 1.3  | 1   | O-Ring D=3.68 x 1.78             | 010130      |              | 0 g     |
| 1.4  | 1   | O-Ring D=44.12 x 2.62            | 010131      |              | 0.8 g   |
| 2    | 1   | Seal kit Typ X 2.0 FDA           | 907130-F    | Wear part    | 4.3 g   |
| 2.1  | 1   | Valve Needle type X 2.0 & 3.0    | 907116      |              | 0.2 g   |
| 2.2  | 1   | Pressure plate type X 2.0        | 907118      |              | 4 g     |
| 2.3  | 1   | HP-seal X 2.0 & 3.0 FDA          | 907117-F    |              | 0 g     |
| 3    | 1   | Valve seat                       | 907214      | Wear part    | 6.1 g   |
| 4    | 1   | Valve case type X 2.0 food safe  | 907811      | Wear part    | 131.1 g |
| 5    | 1   | Cover food safe                  | 907805      |              | 228.4 g |
| 6    | 1   | Orifice Cap M16 x 1.5 food safe  | 907806      |              | 48 g    |
| 7    | 1   | Gland Nut 1/4" food safe         | 701410      |              | 29.3 g  |
| 8    | 1   | Collar 1/4"                      | 711403      |              | 3.1 g   |
| 9    | 1   | Collimation tube L=60 food safe  | 970113      | Wear part    | 89.4 g  |
| 10   | 1   | Jacket food safe                 | 907821      |              | 460 g   |
| 11   | 1   | O-Ring D=9.92 x 2.62             | 010171      | EPDM         | 0.2 g   |
| 12   | 1   | O-Ring D=16.00 x 1.50            | 010172      | EPDM         | 0.1 g   |
| 13   | 1   | O-Ring D=28.25 x 2.62            | 010075      |              | 0.5 g   |
| 14   | 1   | O-Ring D=44.12 x 2.62            | 010131      |              | 0.8 g   |
| 15   | 1   | O-Ring D=52.07 x 2.62            | 010173      | EPDM         | 0.9 g   |
| 16   | 1   | Push-In Fitting D=6mm            | 030476      | Not included | 1.1 g   |
| 17   | 2   | Spacer bush                      | 907809      |              | 3.8 g   |
| 18   | 1   | Orifice Type 94                  | 0094xx      | Not included | 1.1 g   |

|   |  |  |  |            |         |
|---|--|--|--|------------|---------|
| General tolerances ISO 2768-1 mK        |  | Designs and drawings created and produced by the contractor are the contractor's intellectual property and may only be used for the purposes of the order. |  | Weight     | 1.26 kg |
| Amendment:                              |  | Replace for:   |  |            |         |
| A) O-rings waren P-Paste, 24.09.2024 AM |  | Replaced by:   |  |            |         |
|   |  | Drawn  |  | 28.11.2023 | AM      |
|   |  | Checked  |  | 01.12.2023 | PH      |
|   |  | Release  |  | 01.12.2023 | PH      |
|   |  | Index-released   |  | 24.09.2024 | AM      |

Cutting head type X 2.0 FoodSafe

Scale 1 / 2  
 Max. 4150 bar / 60,000 psi

**Components**  
 ALLFI AG - RIEDENMATT 1 - CH-6370 STANS  
 PHONE +41(0)41-618 05 05  
 E-MAIL: sales@allfi.com <http://www.allfi.com>

907820  
 A  
 Index Sheet No. 2  
 No. of sheets 2