

## Assembling - Maintenance

This drawing is appendix A of the installation and maintenance instruction "Cutting head type X 2.0". The complete installation and maintenance instruction is hosted at: [www.allfi.com](http://www.allfi.com)

- Pneumatic-cylinder must be pressurised with air during assembling and disassembling of valve case and collimation tube.
- Stroke adjustment: Stroke 0.6 - 0.8 mm / 0.0235 - 0.0315", air pressure 6-7 bar / 87-101 psi, adjustment range +/- 1 revolution.
- (Attention: Thread of cylinder cover must not be visible)
- Function test with several open and closed cycles.
- After finishing maintenance flush the complete cutting head without nozzle at < 500 bar / 7,200 psi.
- Pressure relief holes must not be covered or closed.

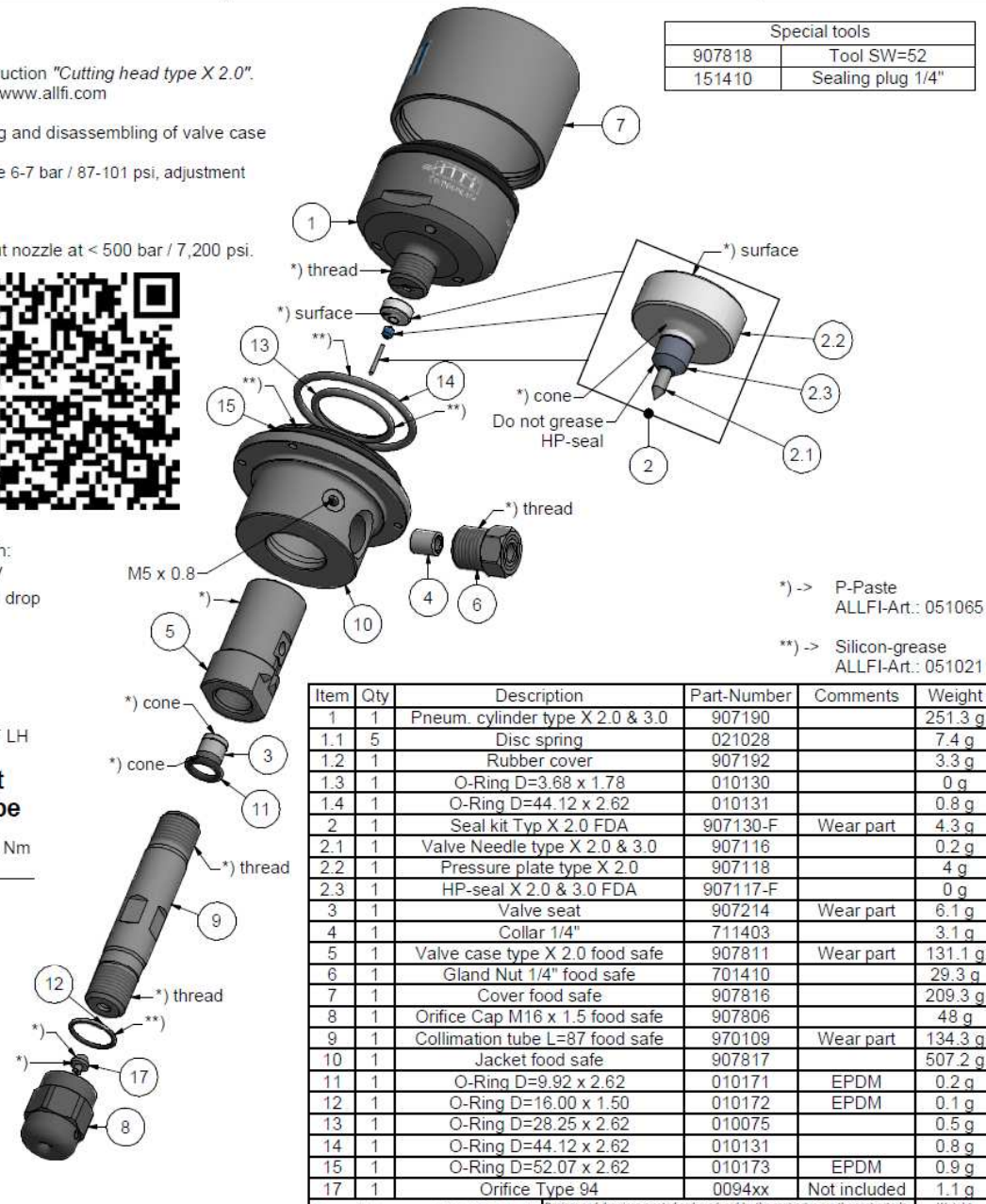
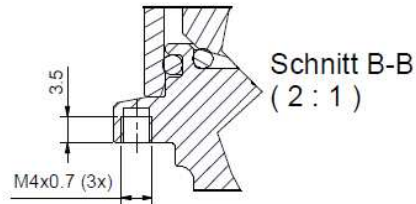
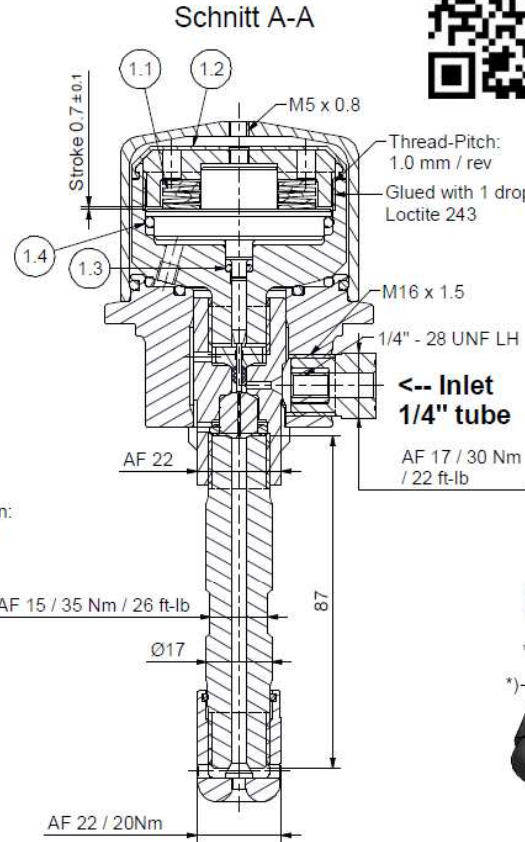
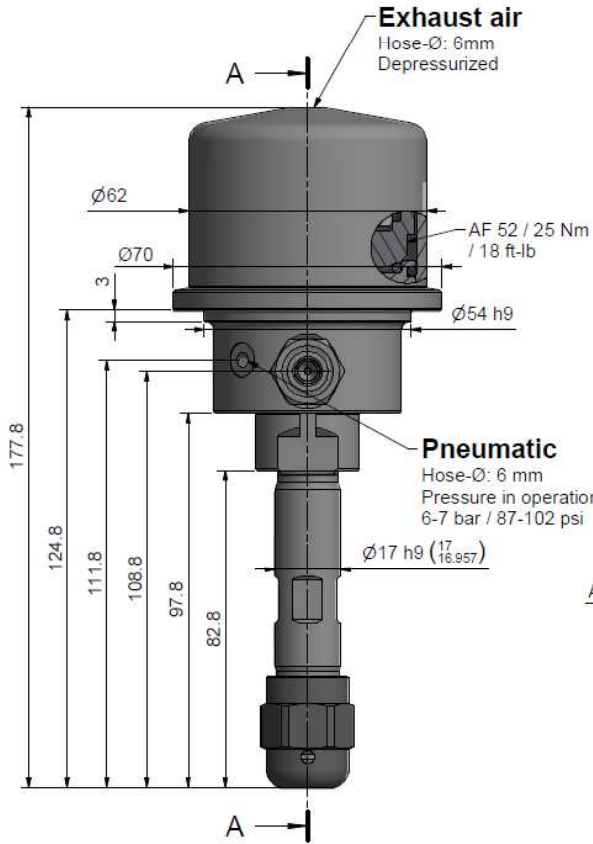
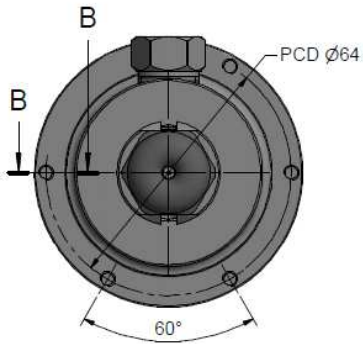

General tolerances ISO 2768-1 mK

Amendment:  
 A) 0132, kleine Ergänzungen, 01.02.2023 AM  
 B) Pos. 16 Luftanschluss weg (Wunsch Kunde), 29.06.2023 AM

Replaced for	-
Replaced by	-
Drawn	11.08.2022 AM
Checked	22.11.2022 GB
Release	22.11.2022 GB
Index-release	07.07.2023 BT

**Cutting head food safe type X 2.0**

Scale 1 : 1

Max. 4150 bar / 60,000 psi

907815

Index B

Sheet-no. 2

No. of sheets 2

ALLFI Components  
 ALLFI AG - RIEDENMATT 1 - CH-6370 STANS  
 PHONE +41(0)41-618 05 05  
 E-MAIL: [sales@allfi.com](mailto:sales@allfi.com) <http://www.allfi.com>