

Assembling - Maintenance

This drawing is appendix A of the installation and maintenance instruction "Cutting head type X 2.0". Complete installation and maintenance instruction refer to QR-Code or: <https://www.alfi.com/en/services/downloads/product-manuals/>

- Pneumatic-cylinder must be pressurised with air during assembling and disassembling of valve case and collimation tube.
- Stroke has to be 0.6 - 0.8 mm / 0.0235 - 0.0315", air pressure 7bar - 100psi, adjustment range +/- 1 revolution.
- Function test with several open and closed cycles.
- After finishing maintenance flush the complete cutting head without nozzle at < 500 bar / 7200 psi.
- Pressure relief holes must not be covered or closed.
- Do not use in combination with the mini filter 2.0



Special tools	
907818	Tool AF=52
151410	Plug male 1/4"

Pneumatic

Hose-Ø: 6 mm
Pressure in operation:
6-7 bar / 87-101 psi

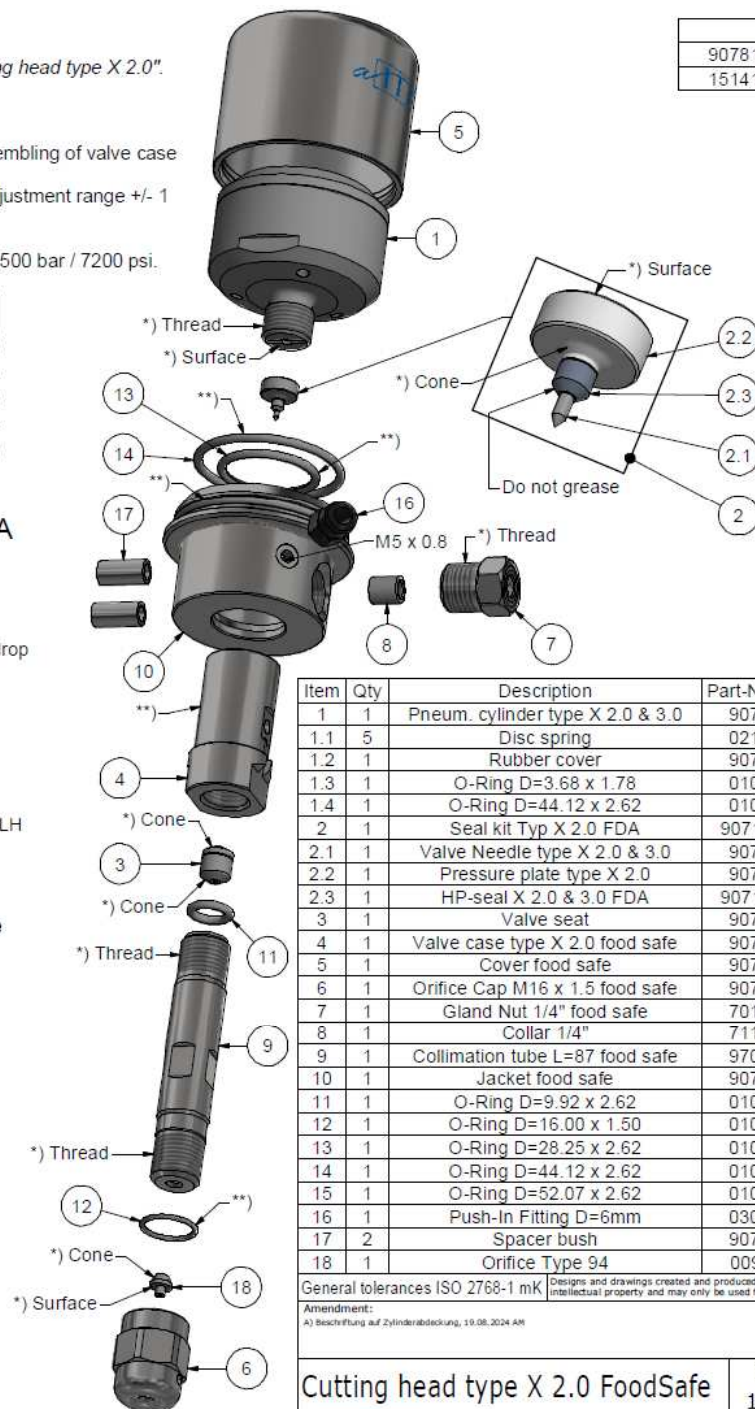
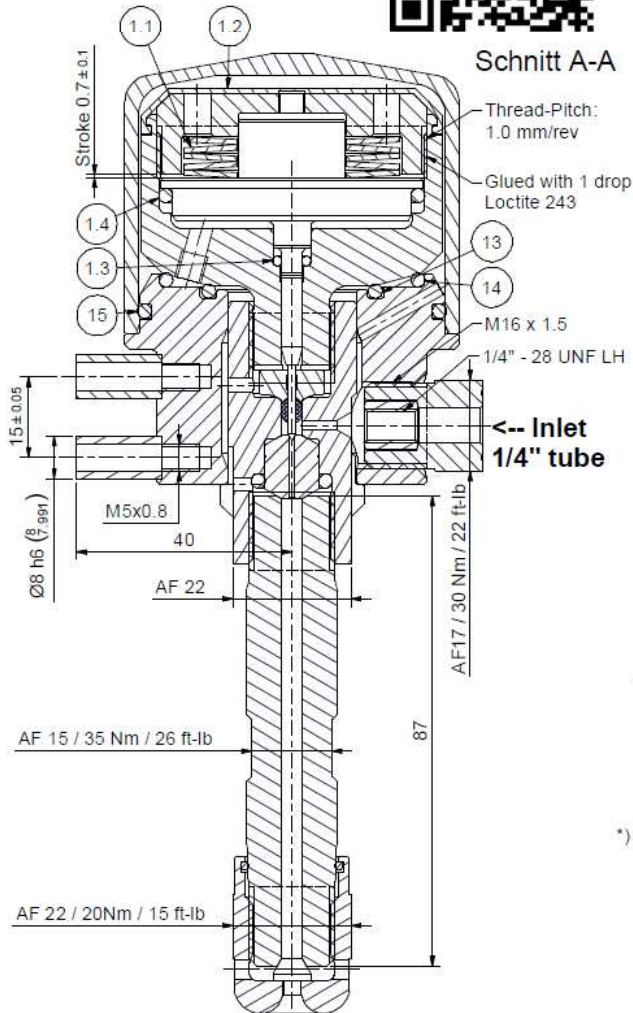
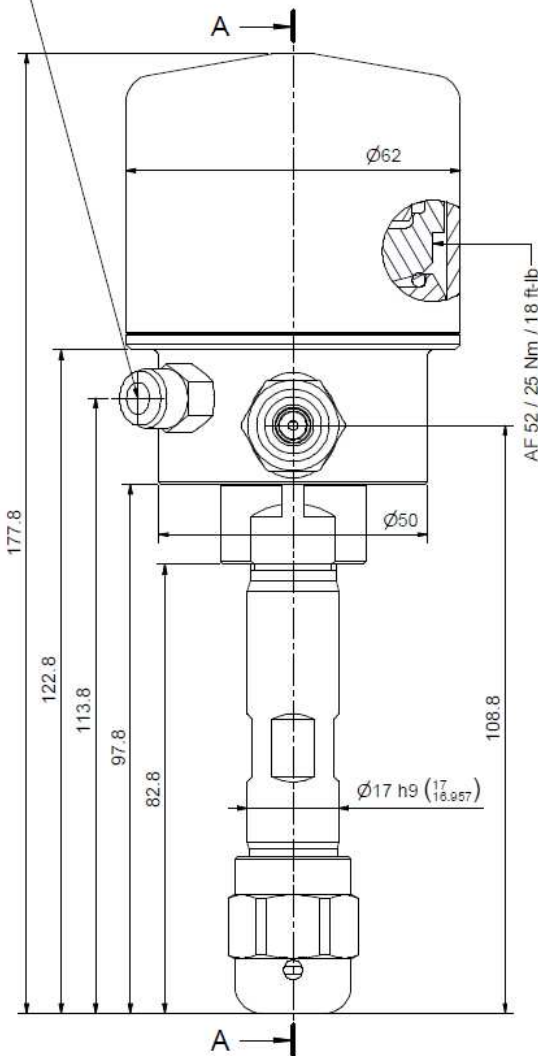

Item	Qty	Description	Part-Number	Comments	Weight	
1	1	Pneum. cylinder type X 2.0 & 3.0	907190		251.3 g	
1.1	5	Disc spring	021028		7.4 g	
1.2	1	Rubber cover	907192		3.3 g	
1.3	1	O-Ring D=3.68 x 1.78	010130		0 g	
1.4	1	O-Ring D=44.12 x 2.62	010131		0.8 g	
2	1	Seal kit Typ X 2.0 FDA	907130-F	Wear part	4.3 g	
2.1	1	Valve Needle type X 2.0 & 3.0	907116		0.2 g	
2.2	1	Pressure plate type X 2.0	907118		4 g	
2.3	1	HP-seal X 2.0 & 3.0 FDA	907117-F		0 g	
3	1	Valve seat	907214	Wear part	6.1 g	
4	1	Valve case type X 2.0 food safe	907811	Wear part	131.1 g	
5	1	Cover food safe	907805		228.4 g	
6	1	Orifice Cap M16 x 1.5 food safe	907806		48 g	
7	1	Gland Nut 1/4" food safe	701410		29.3 g	
8	1	Collar 1/4"	711403		3.1 g	
9	1	Collimation tube L=87 food safe	970109	Wear part	134.3 g	
10	1	Jacket food safe	907814		460 g	
11	1	O-Ring D=9.92 x 2.62	010171	EPDM	0.2 g	
12	1	O-Ring D=16.00 x 1.50	010172	EPDM	0.1 g	
13	1	O-Ring D=28.25 x 2.62	010075		0.5 g	
14	1	O-Ring D=44.12 x 2.62	010131		0.8 g	
15	1	O-Ring D=52.07 x 2.62	010173	EPDM	0.9 g	
16	1	Push-In Fitting D=6mm	030476	Not included	1.1 g	
17	2	Spacer bush	907809		3.8 g	
18	1	Orifice Type 94	0094xx	Not included	1.1 g	
					Weight	1.31 kg

General tolerances ISO 2768-1 mK		Designs and drawings created and produced by the contractor are the contractor's intellectual property and may only be used for the purposes of the order.	
Amendment:		Replace for	-
A) Beschriftung auf Zylinderabdeckung, 19.08.2024 AM		Replaced by	-
		Drawn	20.03.2023 AM
		Checked	14.06.2023 BT
		Release	19.01.2024 PH
		Index-release	13.09.2024 PH
Cutting head type X 2.0 FoodSafe		Scale	1.4 : 1
		Max. 4150 bar / 60,000 psi	
ALLFI AG - RIEDENMATT 1 - CH-6370 STANS PHONE +41(0)41-818 05 05 E-MAIL: sales@alfi.com			
http://www.alfi.com			
Index Sheet- No. of sheets		907810	A