

Assembling - Maintenance

This drawing is appendix A of the installation and maintenance instruction "Cutting head type X 2.0 Slimline".
The complete installation and maintenance instruction is hosted at:
<https://www.alfi.com/en/services/downloads/product-manuals/>

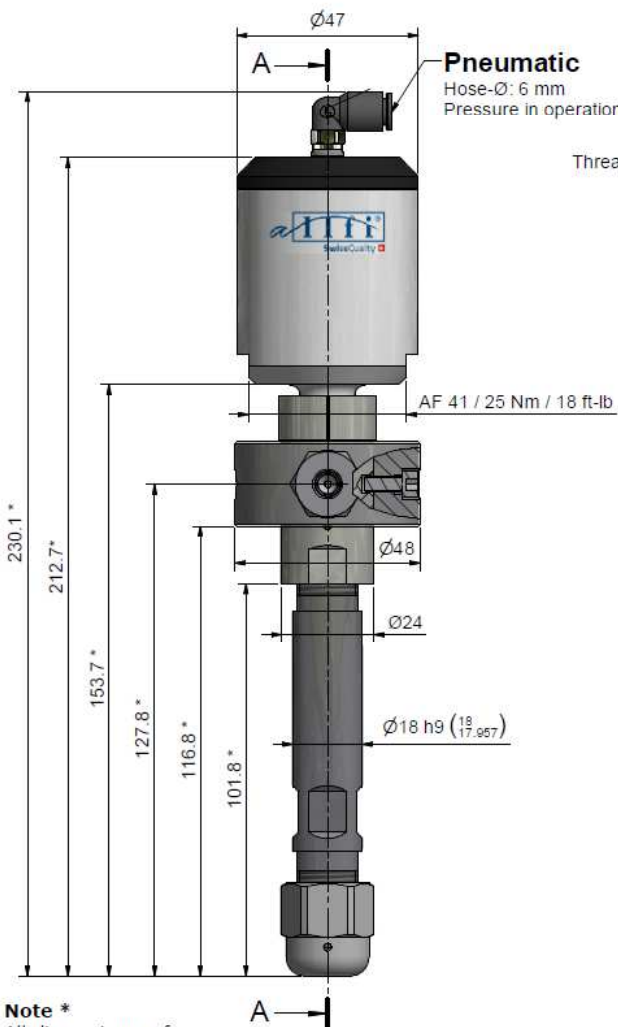

- Pneumatic-cylinder must be pressurised with air during assembling and disassembling of valve case and collimation tube.
- Stroke adjustment: Stroke 0.6 - 0.8 mm / 0.0235 - 0.0315", adjustment range +/- 1 revolution.
(Attention: Thread of cylinder cover must not be visible)
- Function test with several open and closed cycles.
- After finishing maintenance flush the complete cutting head without nozzle at < 500 bar / 7,200 psi.
- Pressure relief holes must not be covered or closed.

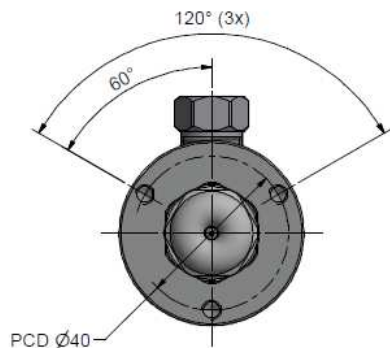

Note *
All dimensions refer to orifice type 90 & 94.
When using type 91 all dimensions will increase by 2.5mm

A-A

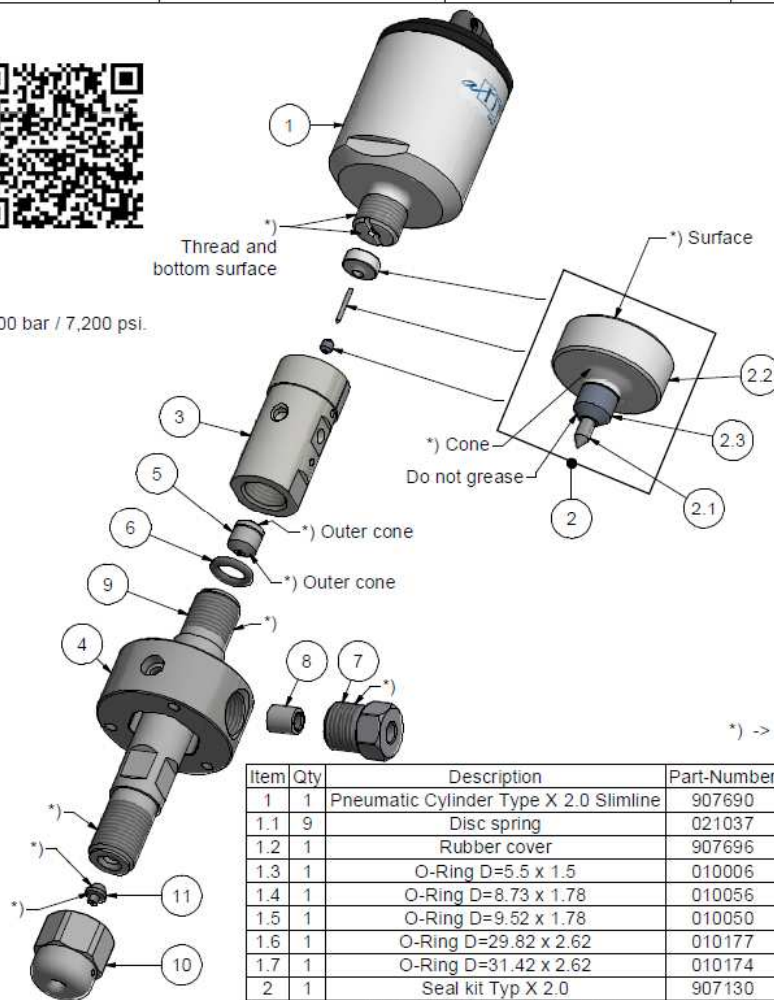
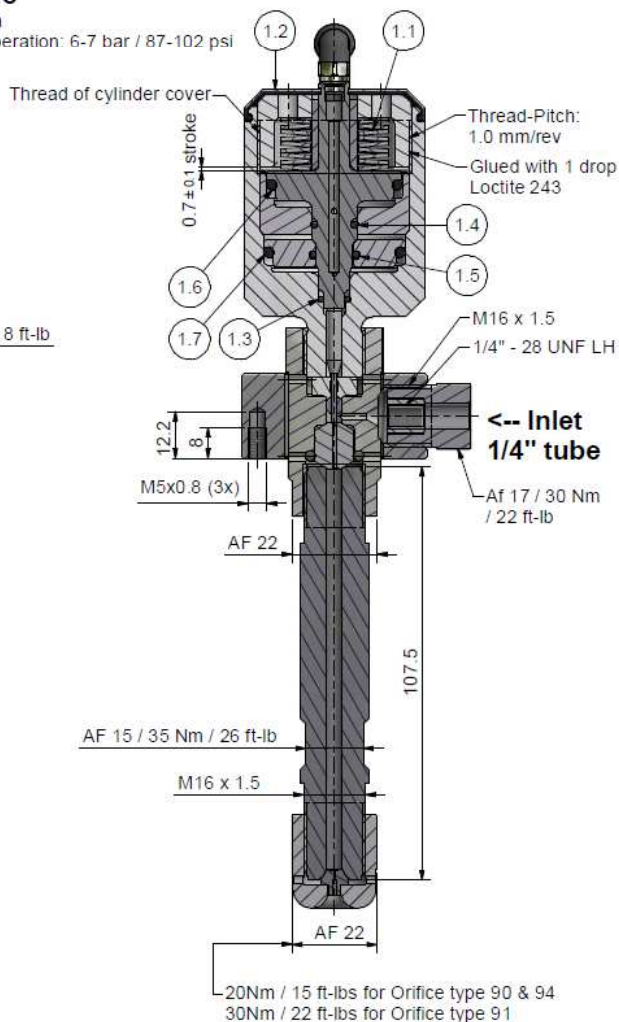

*) -> Assembly-Grease DX
ALLFI-Art.: 051055

Item	Qty	Description	Part-Number	Comments	Weight
1	1	Pneumatic Cylinder Type X 2.0 Slimline	907690		240.8 g
1.1	9	Disc spring	021037		0.5 g
1.2	1	Rubber cover	907696		2.4 g
1.3	1	O-Ring D=5.5 x 1.5	010006		0 g
1.4	1	O-Ring D=8.73 x 1.78	010056		0.1 g
1.5	1	O-Ring D=9.52 x 1.78	010050		0.1 g
1.6	1	O-Ring D=29.82 x 2.62	010177		0.5 g
1.7	1	O-Ring D=31.42 x 2.62	010174		0.6 g
2	1	Seal kit Typ X 2.0	907130	Wear part	4.3 g
2.1	1	Valve Needle type X 2.0 & 3.0	907116		0.2 g
2.2	1	Pressure plate type X 2.0	907118		4 g
2.3	1	HP-seal type X 2.0 & 3.0	907117		0.1 g
3	1	Valve case type X 2.0	907110	Wear part	123.5 g
4	1	Coupling ring X 2.0 & 3.0	907174		202.2 g
5	1	Valve seat	907214	Wear part	6.1 g
6	1	O-Ring D=9.92 x 2.62	010121		0.2 g
7	1	Gland Nut 1/4"	701403		29.1 g
8	1	Collar 1/4"	711403		3.1 g
9	1	Collimation tube - L107.5	900052	Wear part	178 g
10	1	Orifice Cap M16 x 1.5	900060		47.1 g
11	1	Orifice Type 94	0094xx	Not included	1.1 g

General tolerances ISO 2768-1 mK Designs and drawings created and produced by the contractor are the contractor's intellectual property and may only be used for the purposes of the order. Weight 0.84 kg

Amendment:		Replace for:
Replaced by:	-	-
Drawn:	23.11.2022	AM
Checked:	22.02.2023	BT
Release:	03.07.2023	BT
Index-release:		

Cutting Head Type X 2.0 Slimline PWJ

Scale
1 : 1

Max. 4150 bar / 60,000 psi



ALLFI AG - RIEDENMATT 1 - CH-8370 STANS
PHONE +41(0)41-818 05 05 - TELEFAX +41(0)41-818 05 10
E-MAIL: sales@alfi.com <http://www.alfi.com>

907600

Index Sheet-
No. of sheets 2