

6 5 4 3 2 1

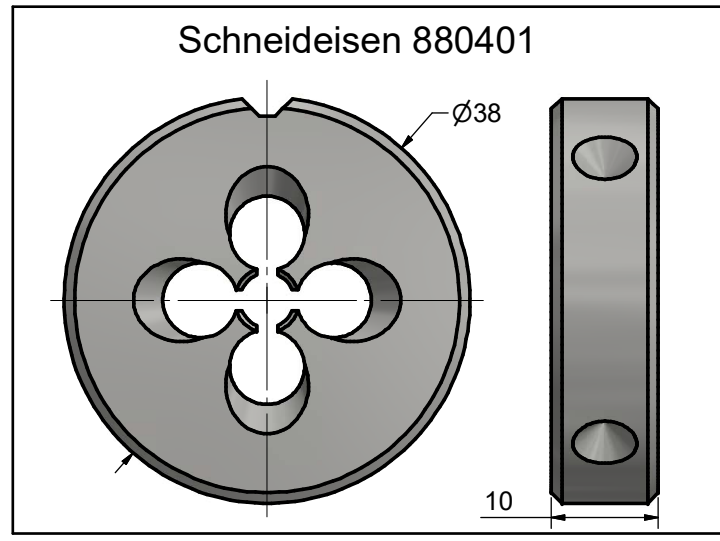
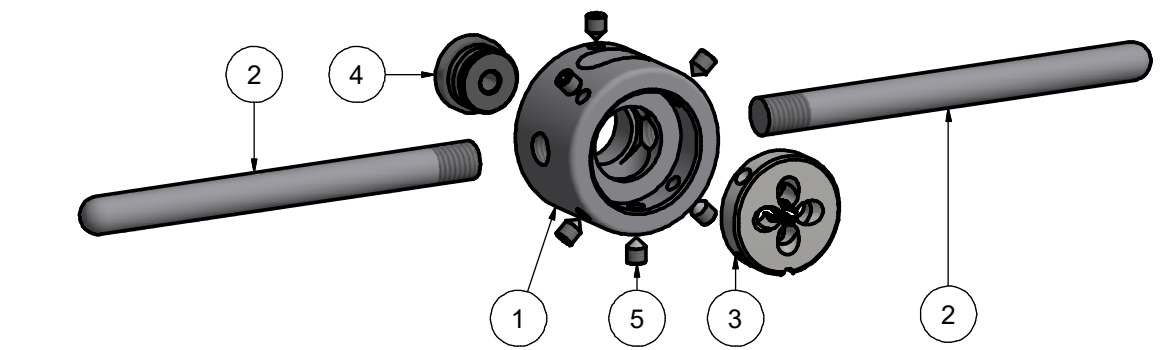
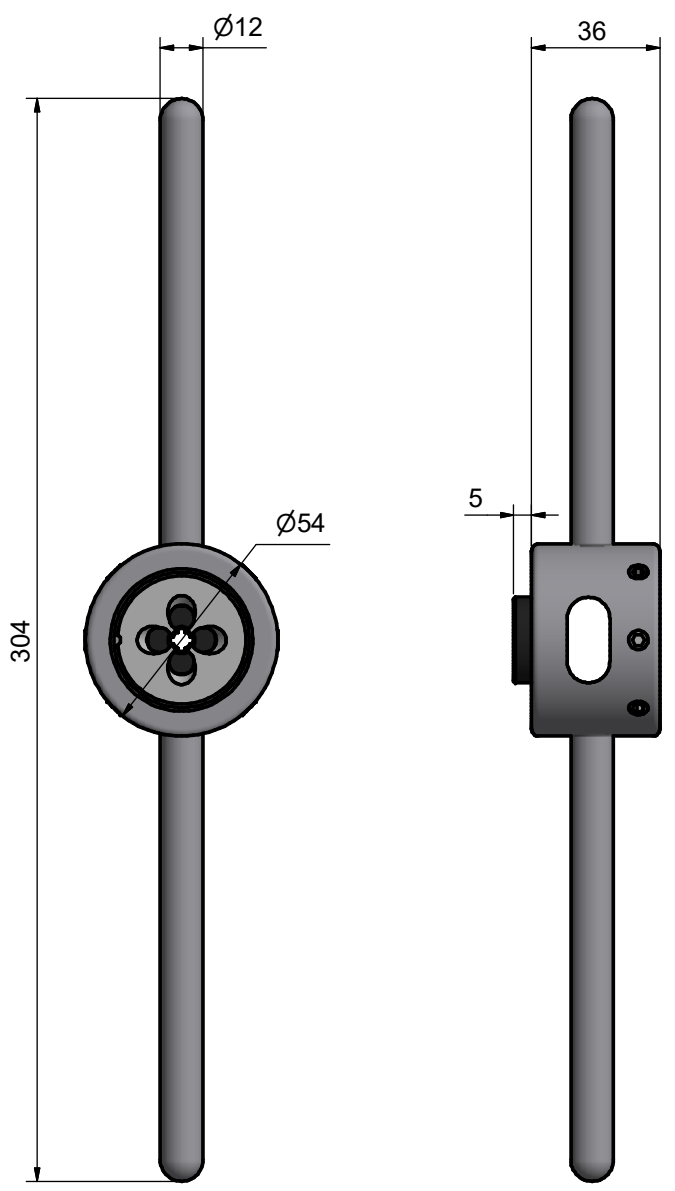

Schneideisen für HP160: 800416

Pos.	Stk.	Gegenstand	Artikel	Kommentare	Gewicht
1	1	Schneideisenhalter	880403		378 g
2	2	Handhebel	880404		123.3 g
3	1	Schneideisen 1/4"-28 UNF LH	880401	For / Für 1.4404	71.1 g
4	1	Führungsbüchse 1/4"	880402		6.4 g
5	6	Gewindestift M6x8 mit Spitz	000017		0.1 g

Allgemeintoleranzen ISO 2768-1 mK Diese Zeichnung ist unser geistiges Eigentum und darf ohne unsere Einwilligung weder kopiert, vervielfältigt, weitergegeben, noch zur Ausführung benutzt werden Gewicht 0.70 kg

Änderungen:	Ersatz für	-
	Ersetzt durch	-
	Gezeichnet	16.06.2011 sl

Gewindeschneidwerkzeug 1/4"	Masstab 1 : 1	Geprüft	17.01.2018	RB
		Freigabe	17.01.2018	RB
		Indexfreigabe		

Gewinde 1/4"-28 UNF LH

allfi
Components
ALLFI AG - RIEDENMATT 1 - CH-6370 STANS
TELEFON +41(0)41-618 05 05
E-MAIL: sales@allfi.com <http://www.allfi.com>

880400	Index	-	Blatt-Nr.	1
			Anzahl Blätter	2

6 5 4 3 2 1

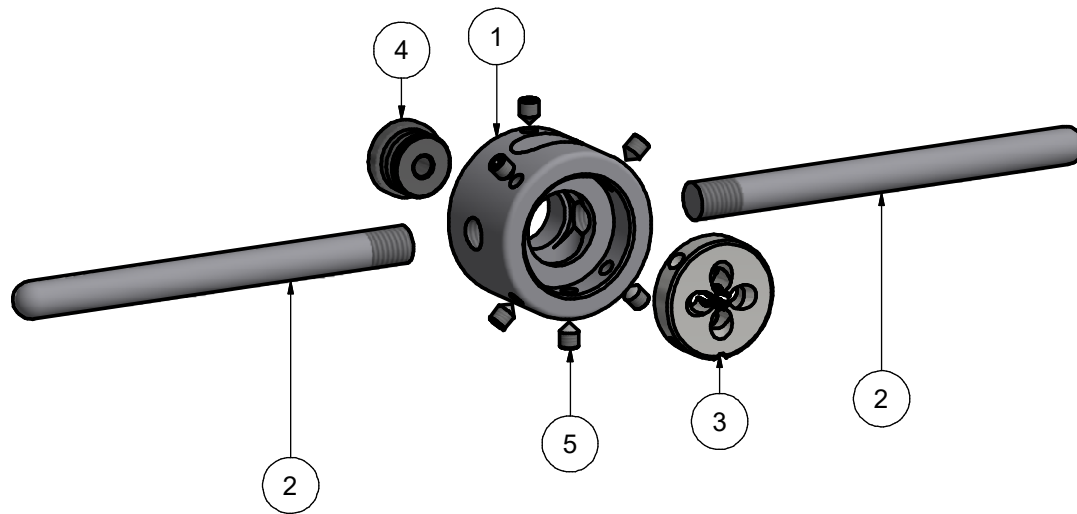
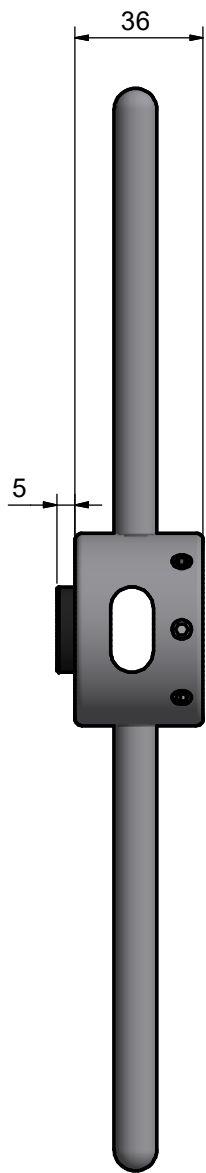
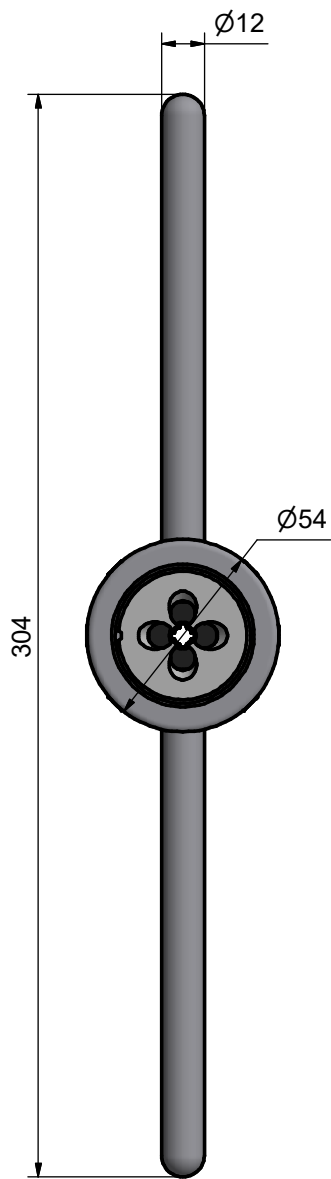

Threading Die for HP160: 880416

Item	Qty	Description	Part-Number	Comments	Weight
1	1	Die Holder	880403		378 g
2	2	Lever	880404		123.3 g
3	1	Threading Die 1/4"-28 UNF LH	880401		71.1 g
4	1	Alternate Guide Bushing 1/4"	880402		6.4 g
5	6	Set screw	000017		0.1 g

General tolerances ISO 2768-1 mK Designs and drawings created and produced by the contractor are the contractor's intellectual property and may only be used for the purposes of the order. Weight 0.70 kg

Amendment:		Replace for	-
		Replaced by	-
		Drawn	16.06.2011 sl

Manual Threading Cutting Tool 1/4"	Scale 1 : 1	Checked	17.01.2018	RB
		Release	17.01.2018	RB
		Index-release		

allfi
 Components

ALLFI AG - RIEDENMATT 1 - CH-6370 STANS
 PHONE +41(0)41-618 05 05
 E-MAIL: sales@allfi.com

<http://www.allfi.com>

Thread 1/4"-28 UNF LH

880400	Index	-	Sheet-No.	2
			No. of sheets	2